

Slow-Wave Causal Model for Multi Layer Ceramic Capacitors

Istvan Novak
Gustavo Blando
Jason R. Miller

DesignCon 2006
11-TA4
February 2006



Agenda

- Present modeling options
- Slow-wave causal model
 - Unit-cell model
 - Lossy transmission-line model
- Correlations
 - Test fixture characterization
 - Convergence of unit-cell model
 - Correlation results
- Conclusions and future work

Present Modeling Options (1)

Measured parameters of 10uF 0508 MLCC

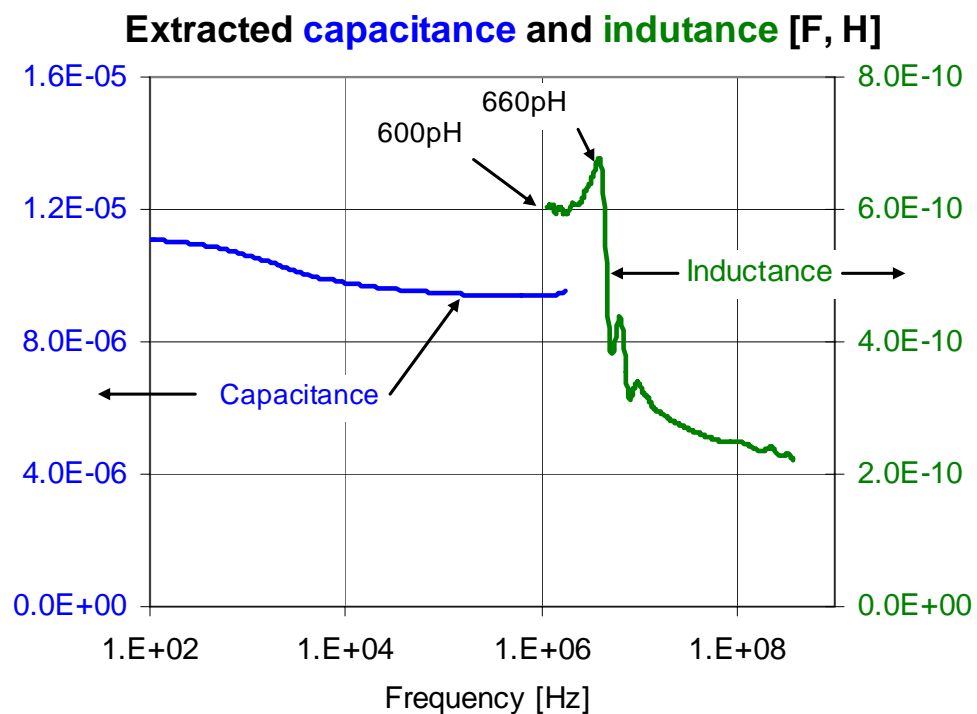
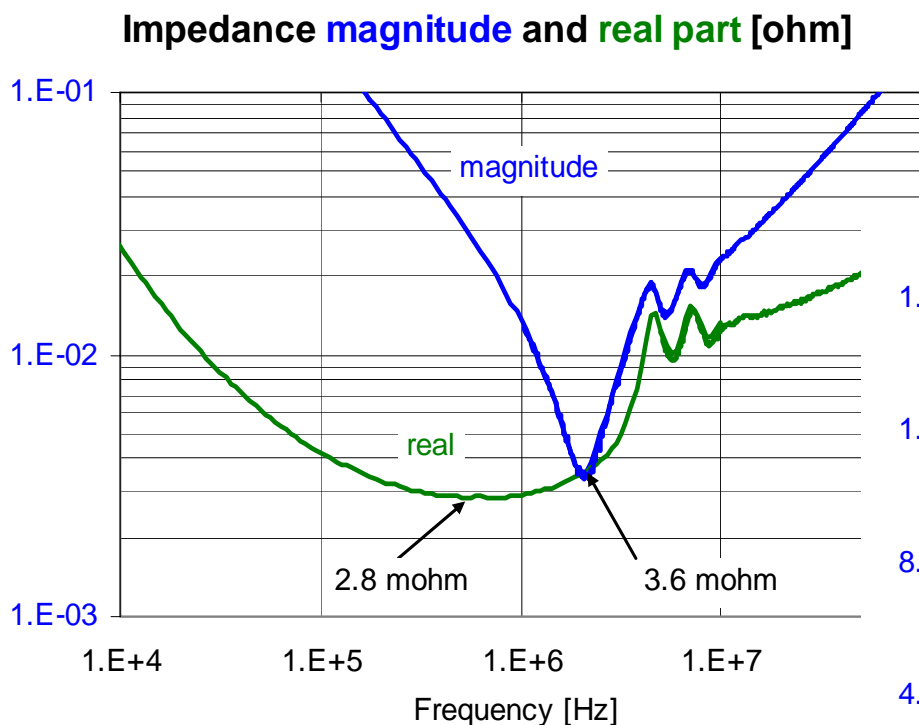

Present Modeling Options (2)

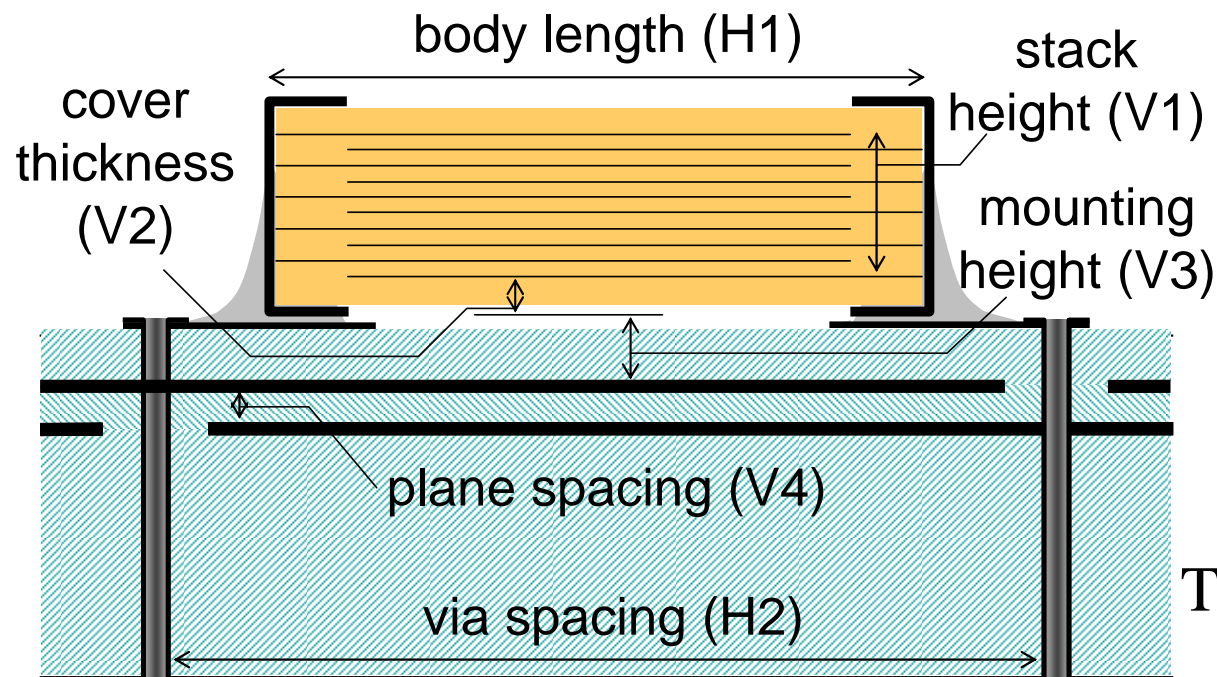

Typical simple model:

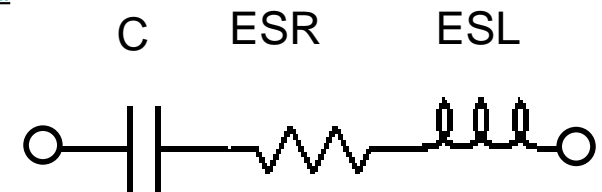

Present Modeling Options

Bedspring model

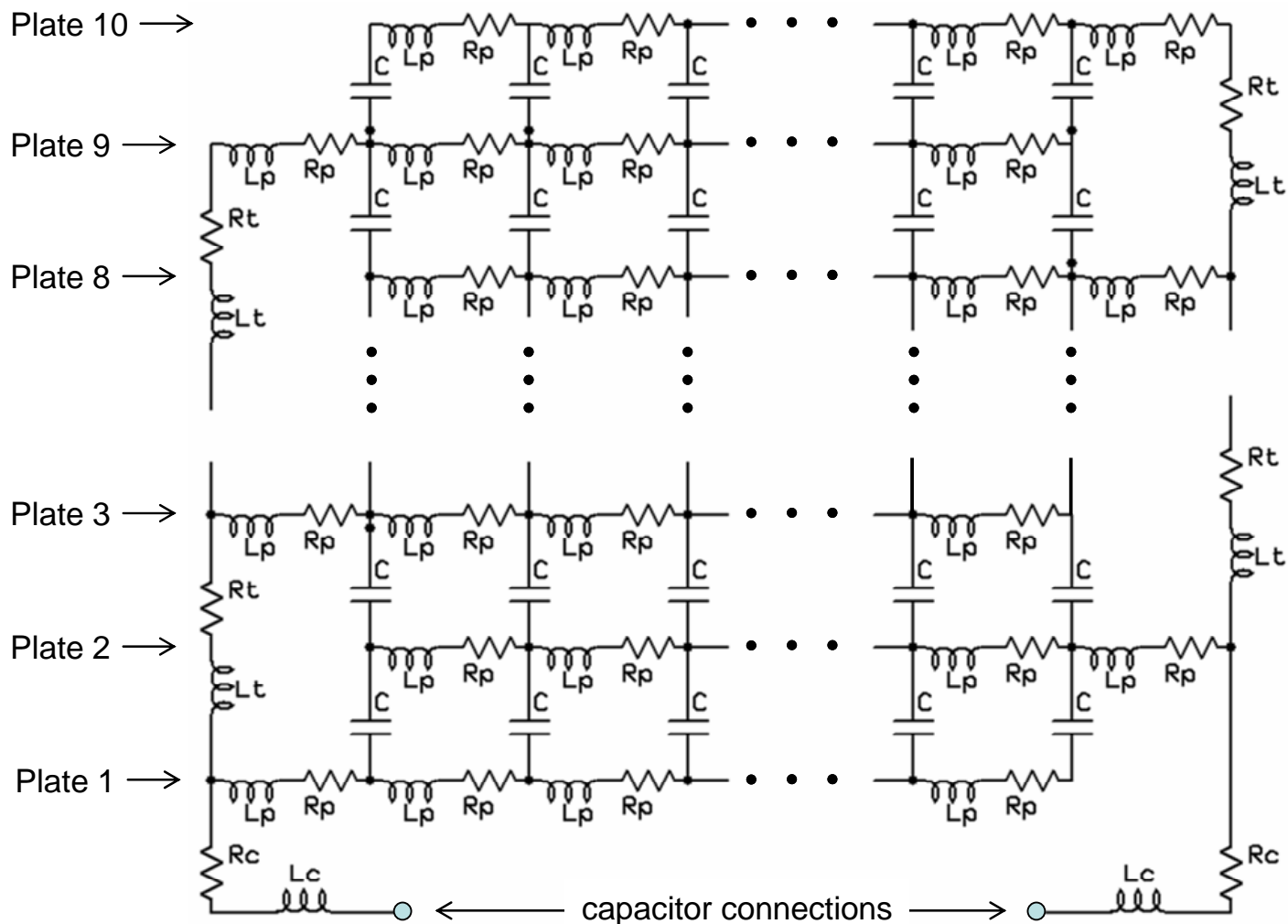

Present Modeling Options

Simulated impedance with bedspring model

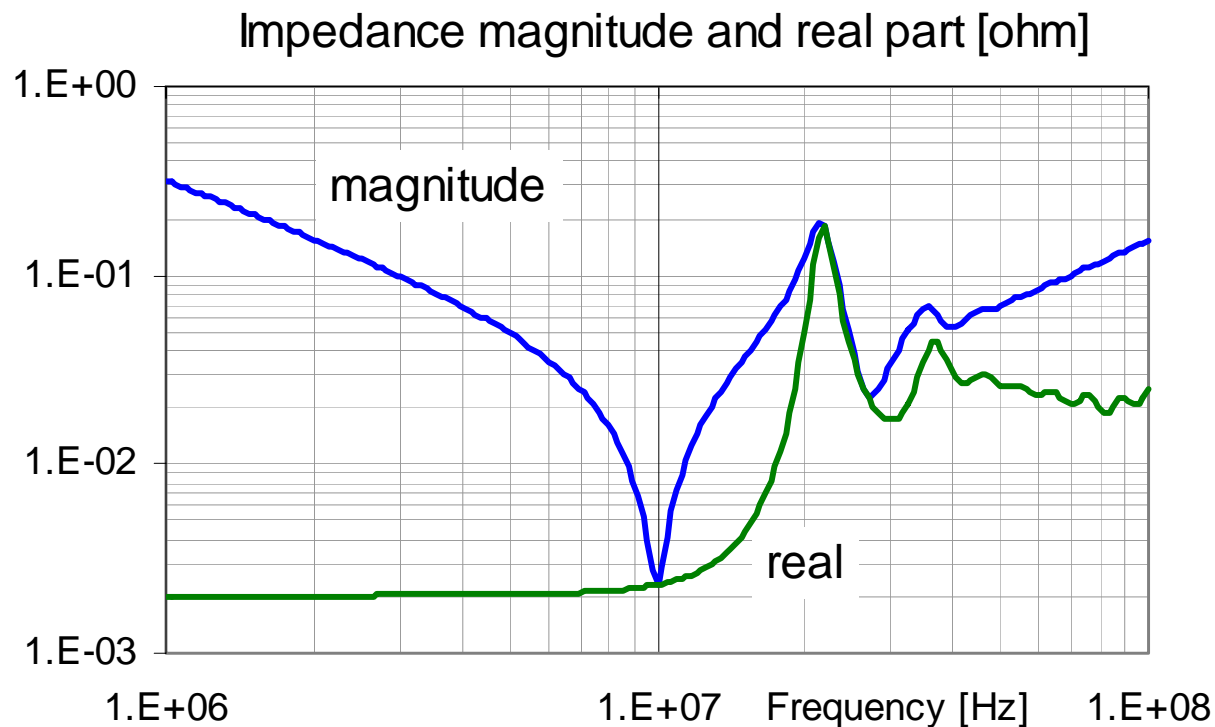

C [F]:	5.00E-09
Lp [H]:	1.00E-11
Rp [ohm]:	1.00E-03
Lt [H]:	1.00E-10
Rt [ohm]:	1.00E-04
Lc [H]:	1.00E-10
Rc [ohm]:	0.00E+00

Present Modeling Options

Current distribution at SRF from bedspring model

Plate current:

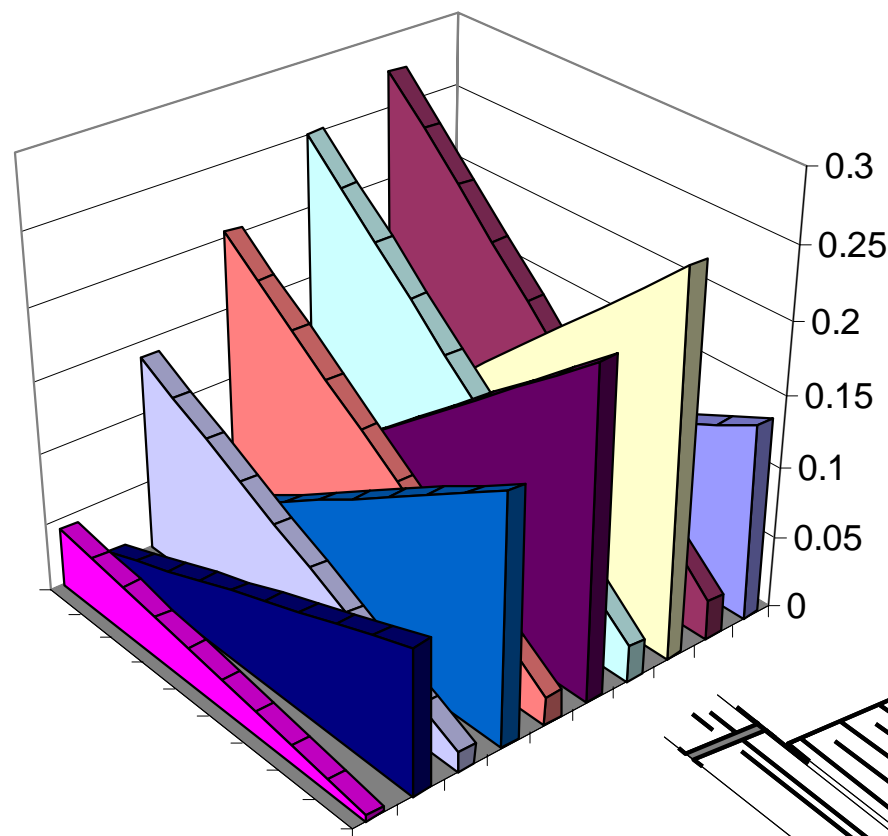

Dielectric current:

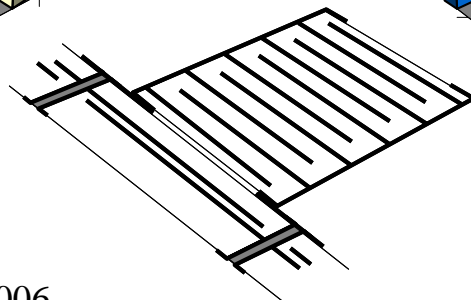
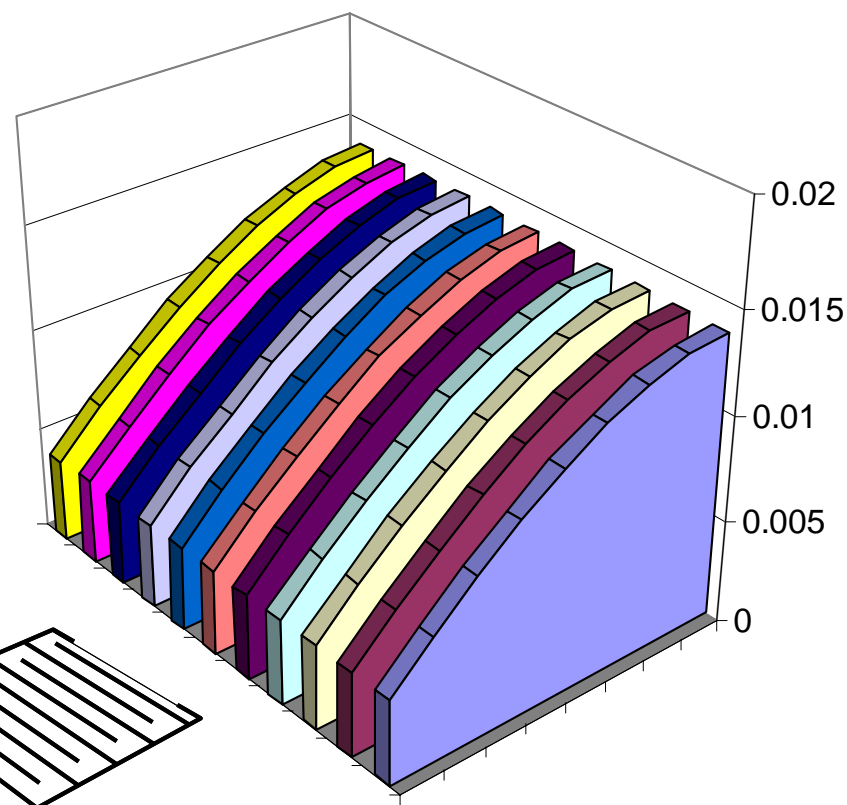

Present Modeling Options

Black-box model, $L(f)$, $C(f)$

$$L_a = L_{\text{inf}} + \frac{L_1}{\left(1 + \left(\frac{f}{f_{L1}}\right)^2\right)^{m_{L1}}} + \frac{L_2}{1 + \exp\left\{\frac{\log(f) - \log(f_{L2})}{m_{L2}}\right\}}$$

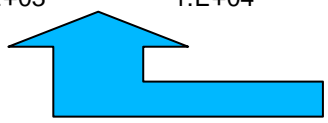
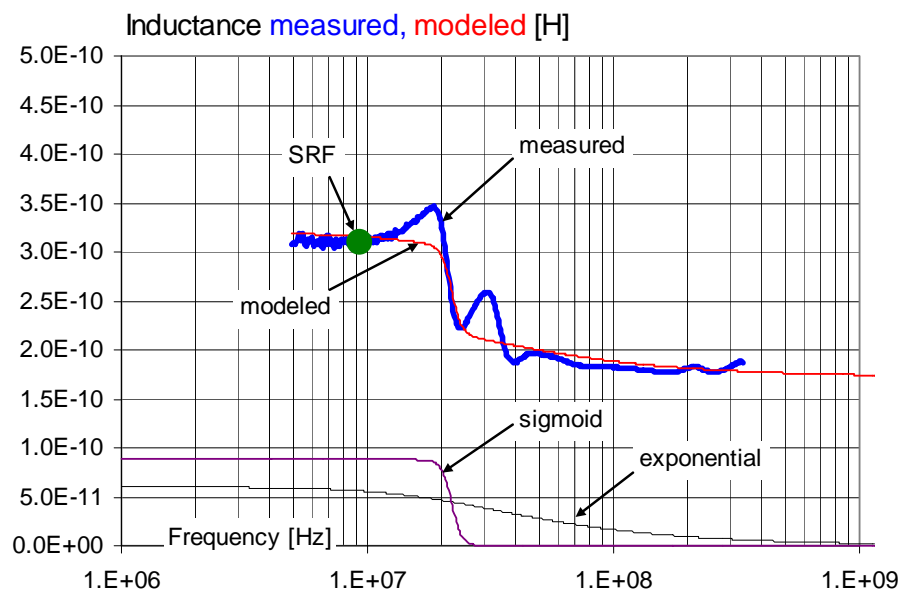
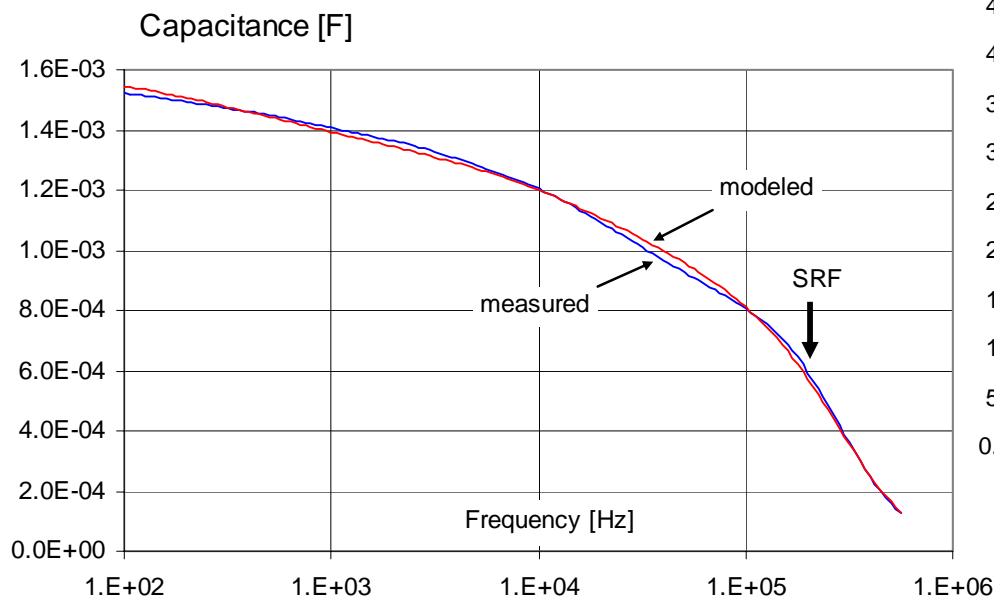
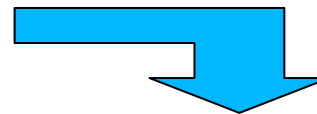

$$C_a = \frac{C_o}{\left\{1 + \left(\frac{f}{f_{C1}}\right)^2\right\}^{m_{C1}} \left\{1 + \left(\frac{f}{f_{C2}}\right)^2\right\}^{m_{C2}} \left\{1 + \left(\frac{f}{f_{C3}}\right)^2\right\}^{m_{C3}}}$$

Present Modeling Options

Limitations

R-L-C models

- Simple model does not capture secondary resonances
- Ladder models are causal, but complex
- Bed-spring model is most accurate, but most complex

Black-box models

- Hard to guarantee causality

Slow-Wave Causal Model

The unit cell (1)

MLCCs are periodically loaded transmission lines

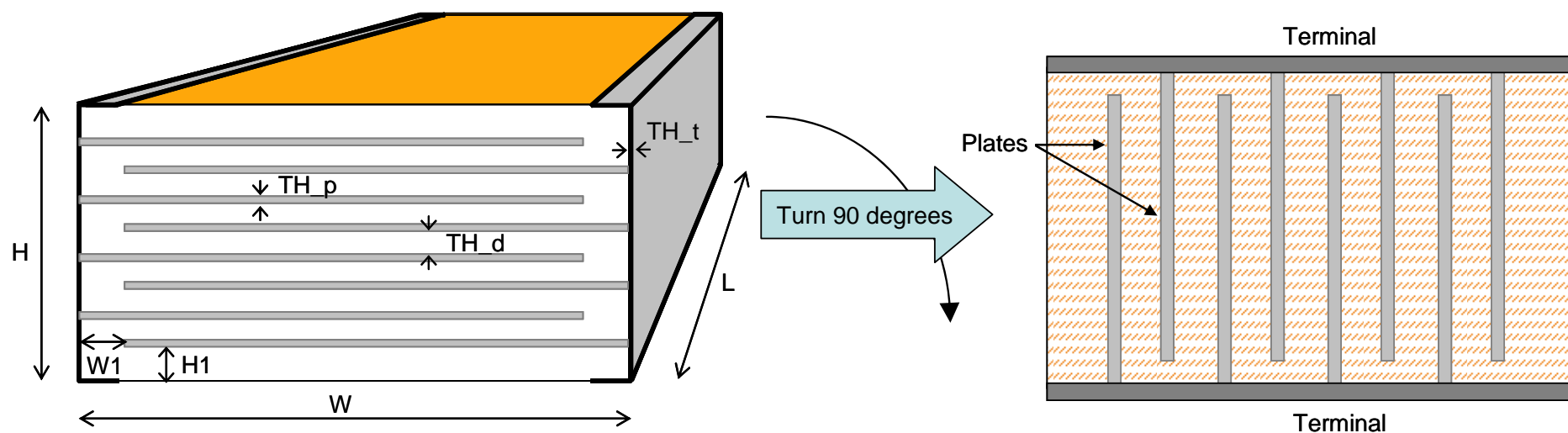

Slow-Wave Causal Model

The unit cell (2)

Each capacitor plate pair forms one unit cell of load impedance
 Unloaded end pieces are formed by the empty cover layers

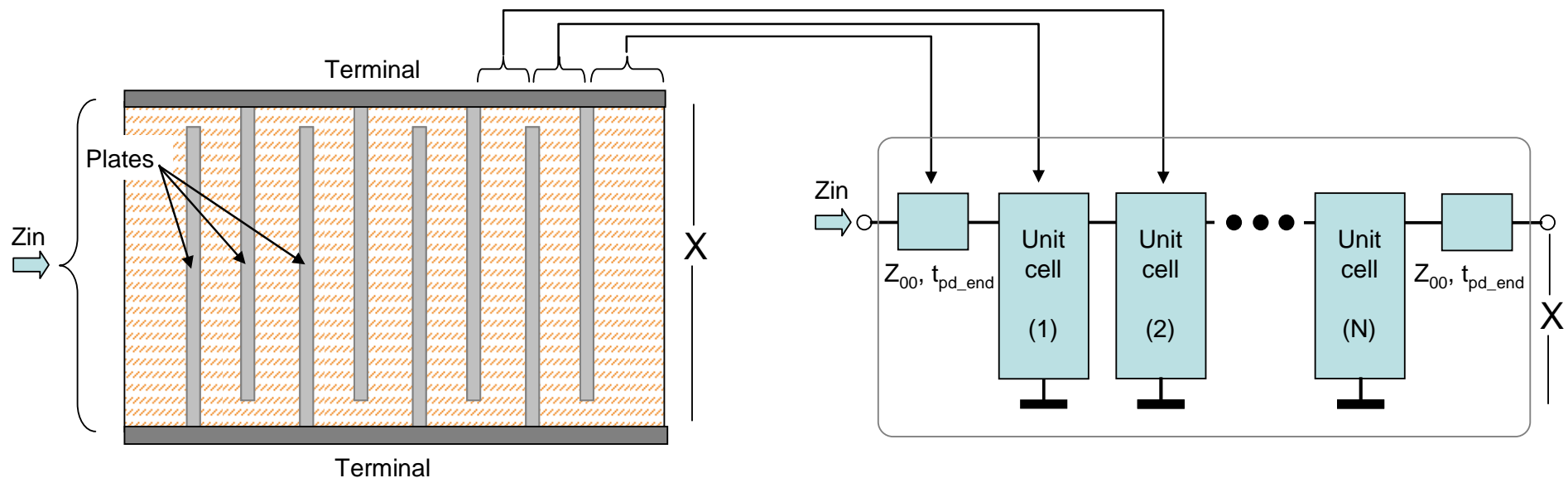

Slow-Wave Causal Model

Generating unit cell parameters from geometry

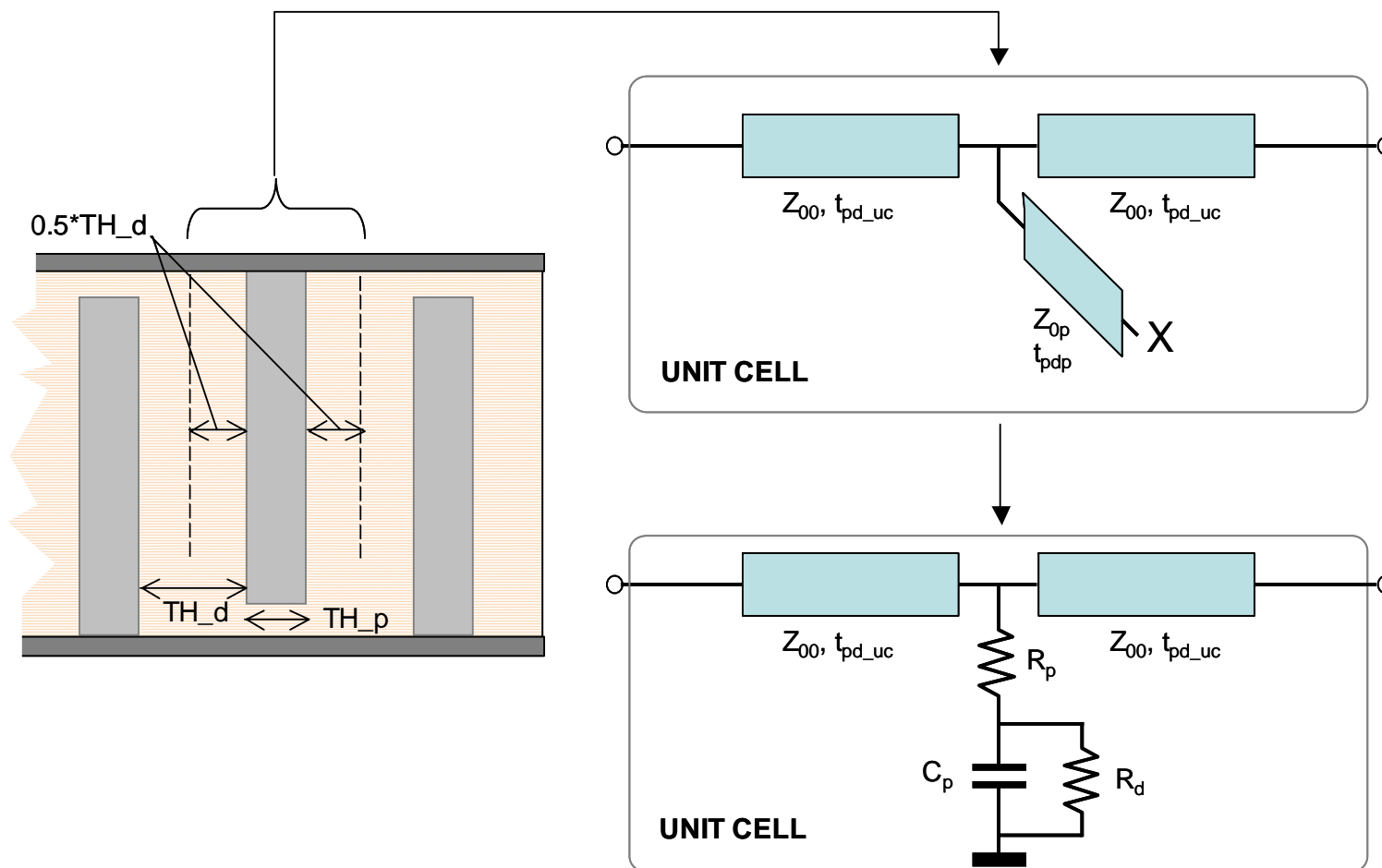

The Lossy Transmission Line Model

Transforming the unit cell

Terminal resistance and inductance

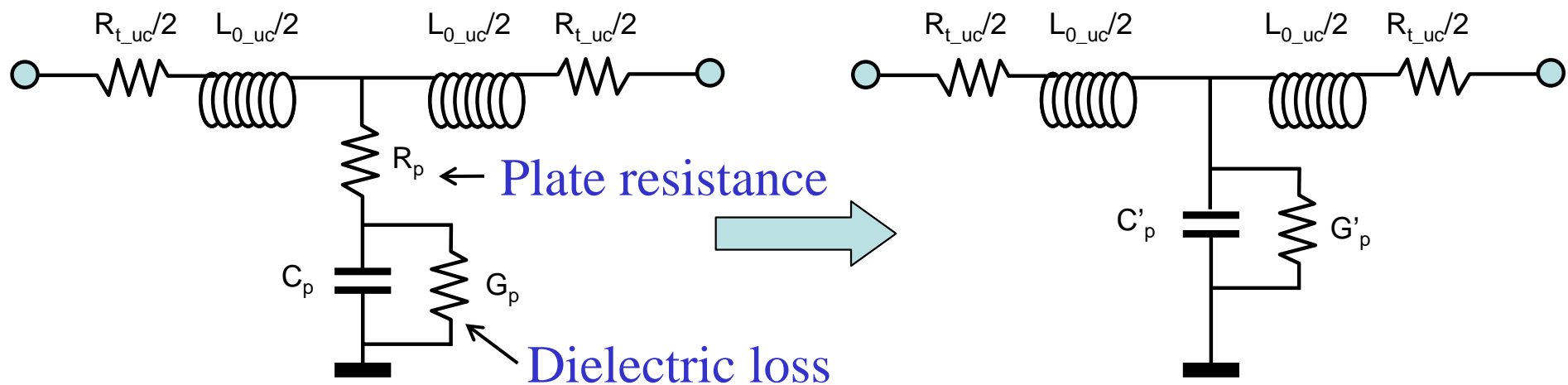

$$\omega_p = \frac{1}{R_p C_p} \quad C'_p = \frac{C_p}{1 + \left(\frac{\omega}{\omega_p}\right)^2} \quad \text{and} \quad G'_p = G_p + \omega C'_p \frac{\omega}{\omega_p}$$

The Lossy Transmission Line Model

Simplified model

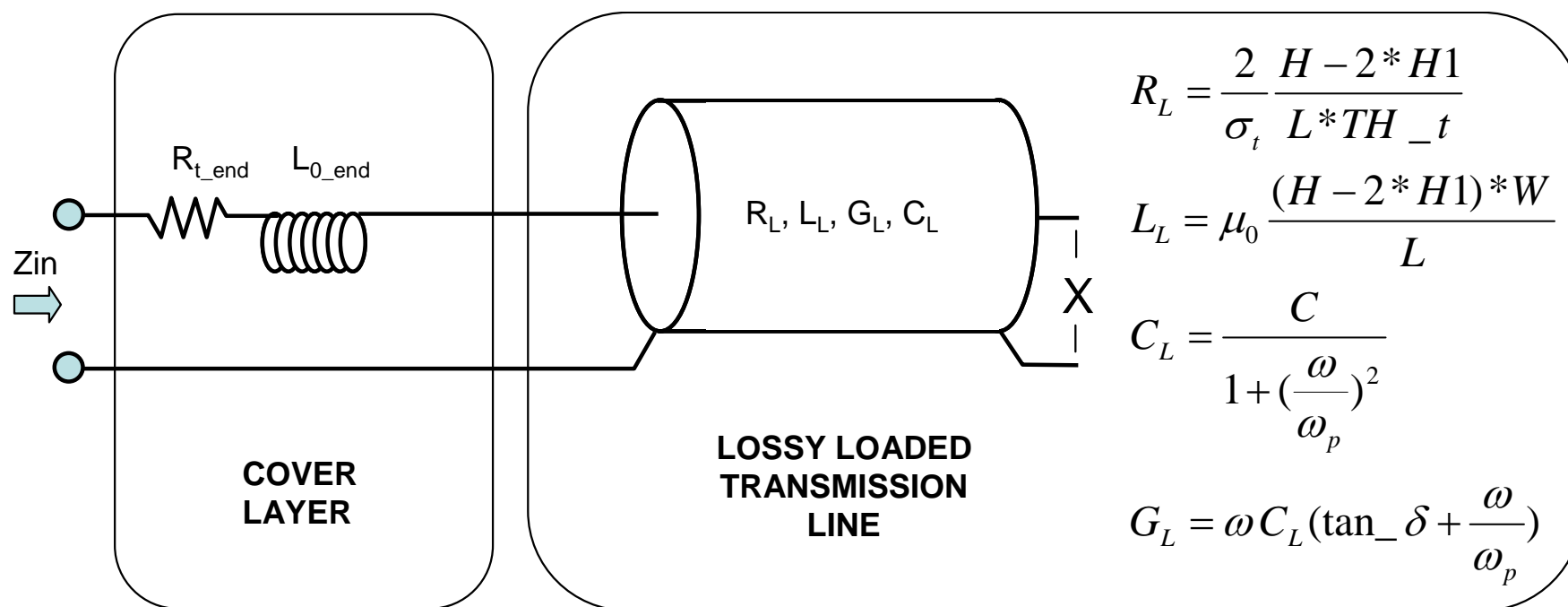

Correlations (1)

Test fixture characterization

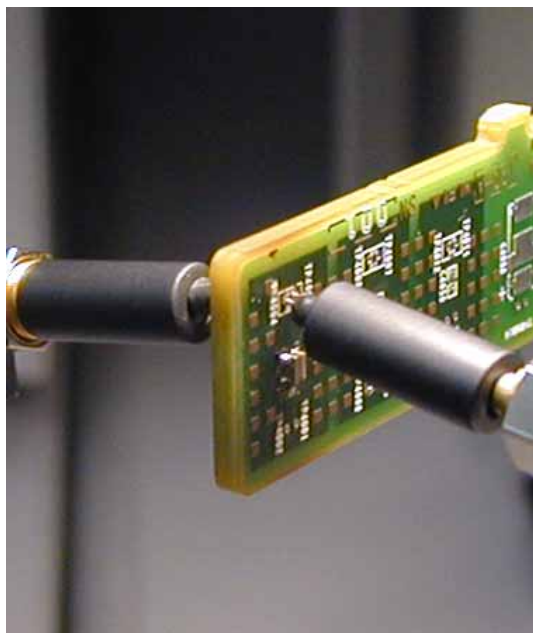

Three 7-mil blind vias connect to layer 21 with 25-mil center-to-center spacing. Three 12-mil blind vias connect to layer 20, with 25-mil center-to-center spacing.

Horizontal spacing between the two columns of vias is 50 mils.

The capacitor pads are 80x35-mil rectangular shapes with 20-mil air gap.

400x600 mil plane shapes with 2.1-mil separation on layers 20 and 21.

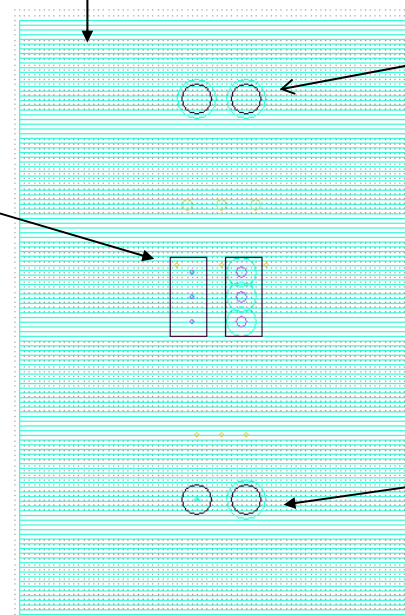

Through holes for test site on layers 2-3.

Through holes on 50-mil center-to-center spacing for connecting semirigid probes.

Correlations (2)

Test fixture capacitance

Capacitance extracted from bare fixture's impedance

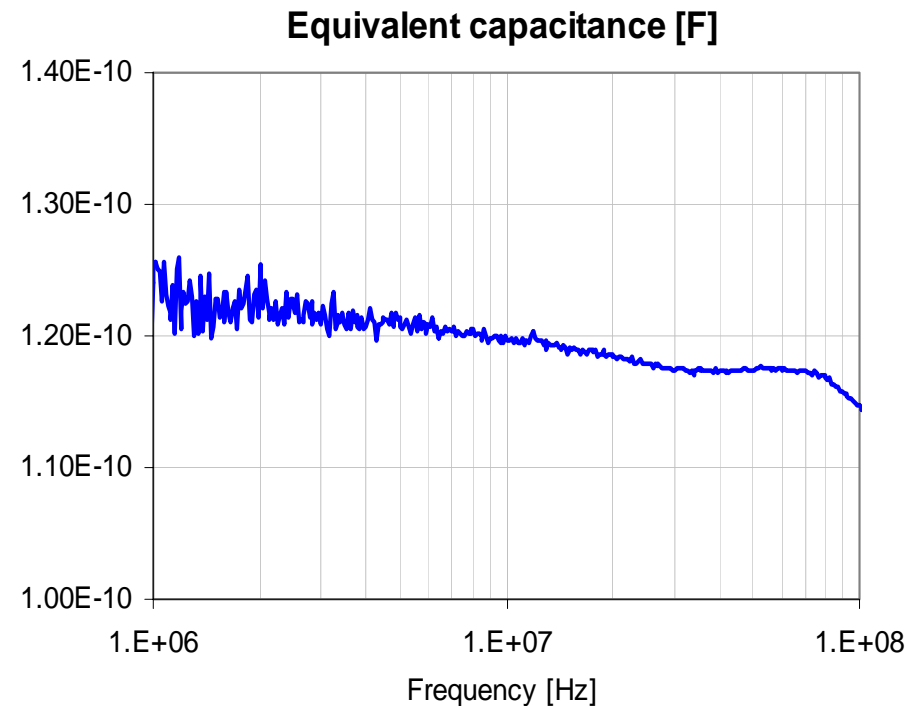
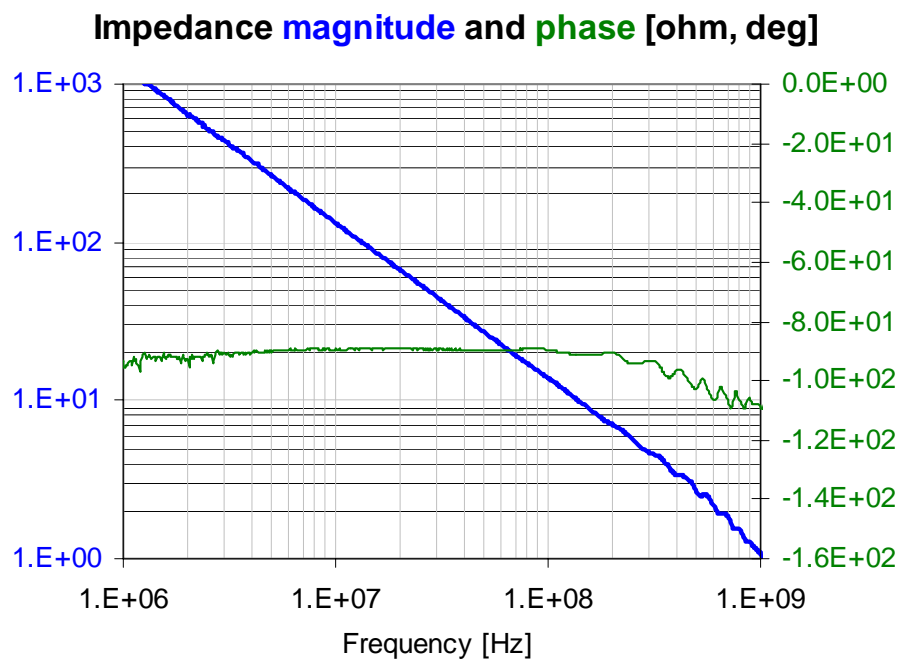

Correlations (3)

Test fixture inductance

Inductance extracted from shorted fixture's impedance

$$L(f) = L_{\text{inf}} + \frac{\Delta L}{1 + \left(\frac{f}{f_R}\right)^N}$$

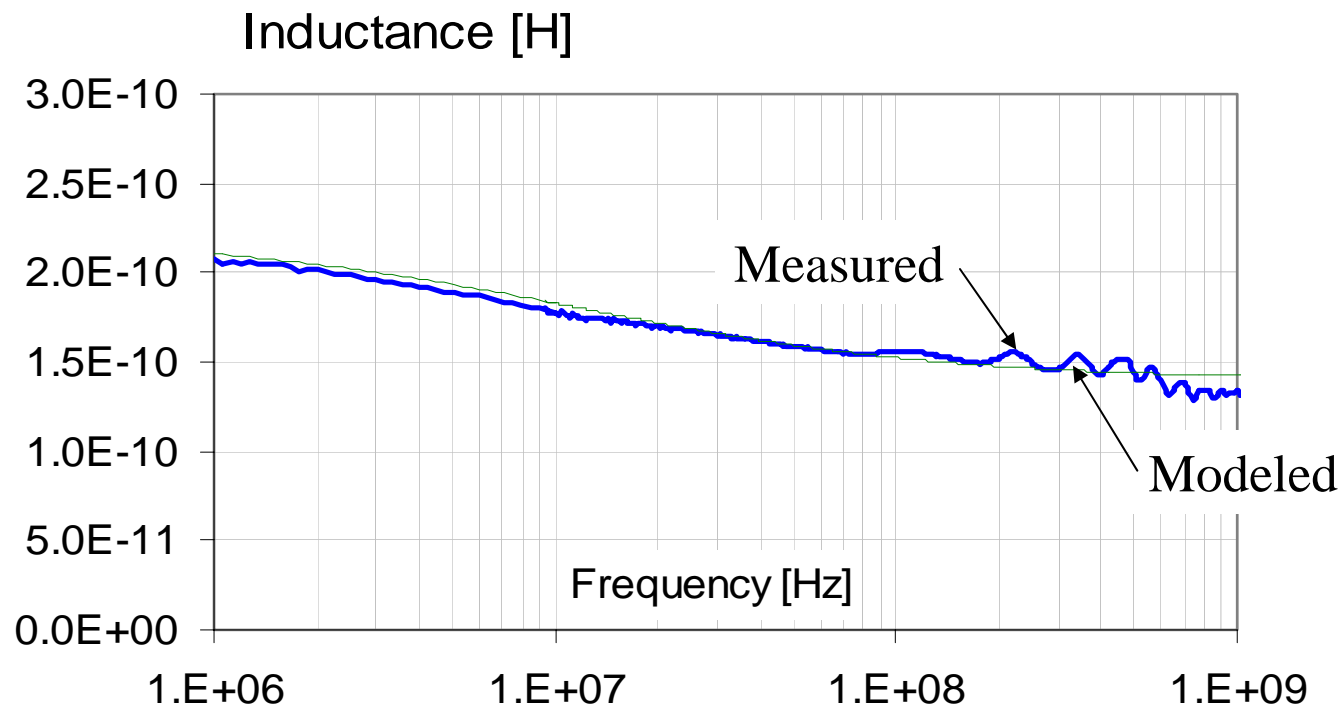

Correlations (4)

Test fixture resistance

Resistance extracted from shorted fixture's impedance

$$R(f) = R_{DC} \left(1 + \left(\frac{f}{f_R} \right)^N \right)$$

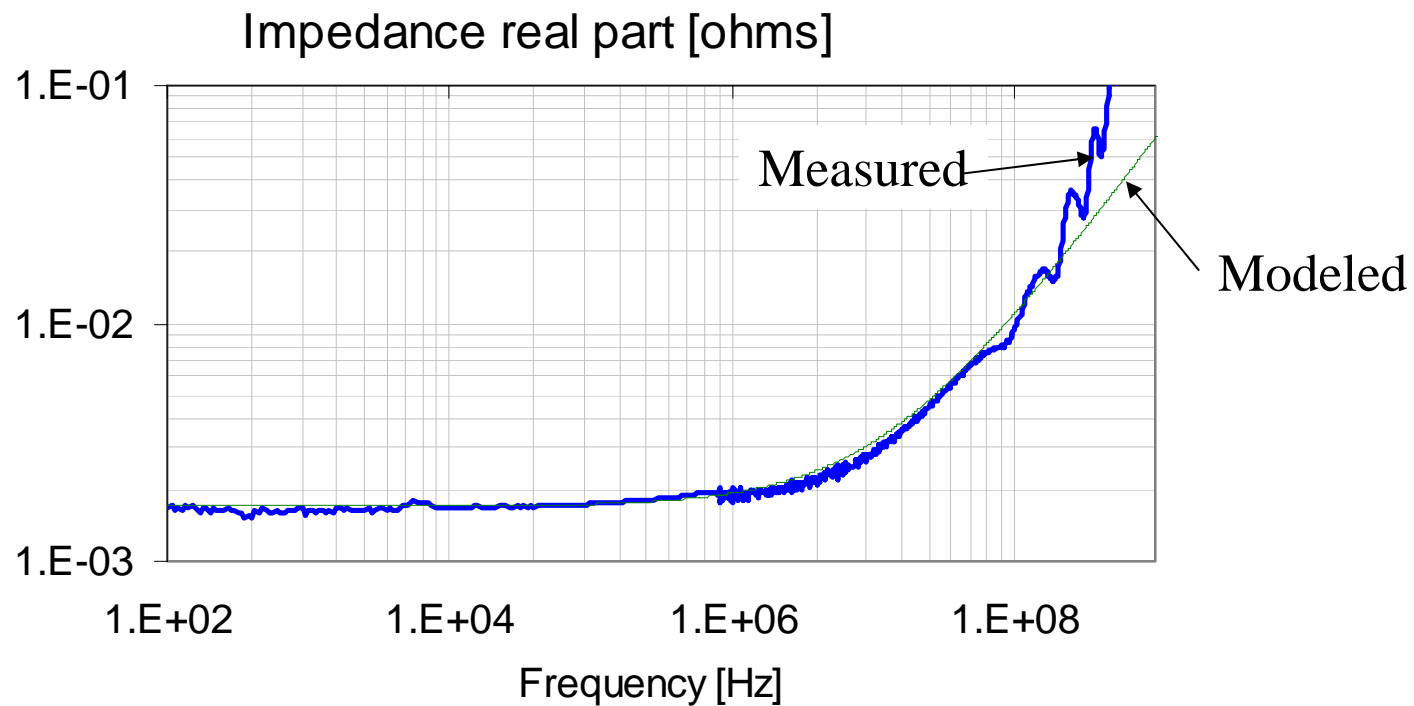

Correlations (5)

Convergence of unit cell model

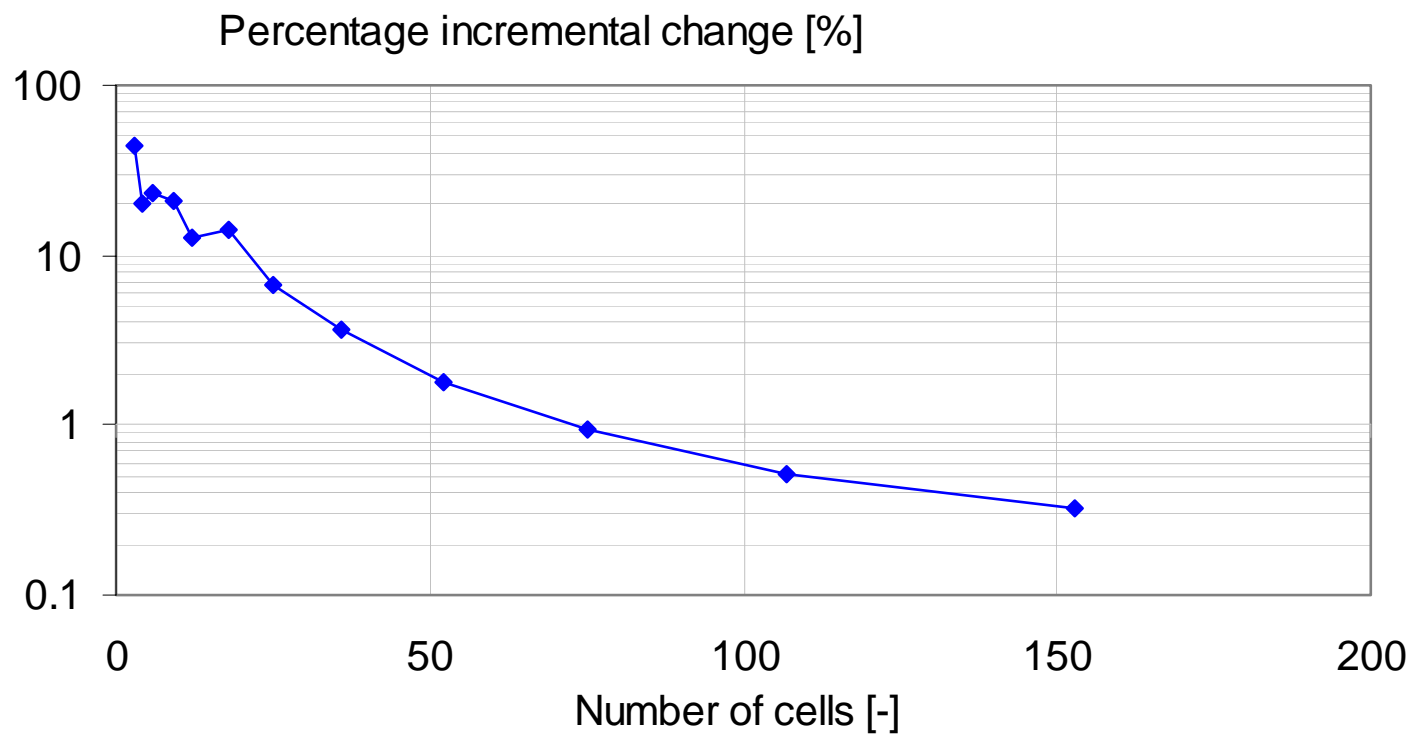

Correlation below SRF

One loss tangent domain

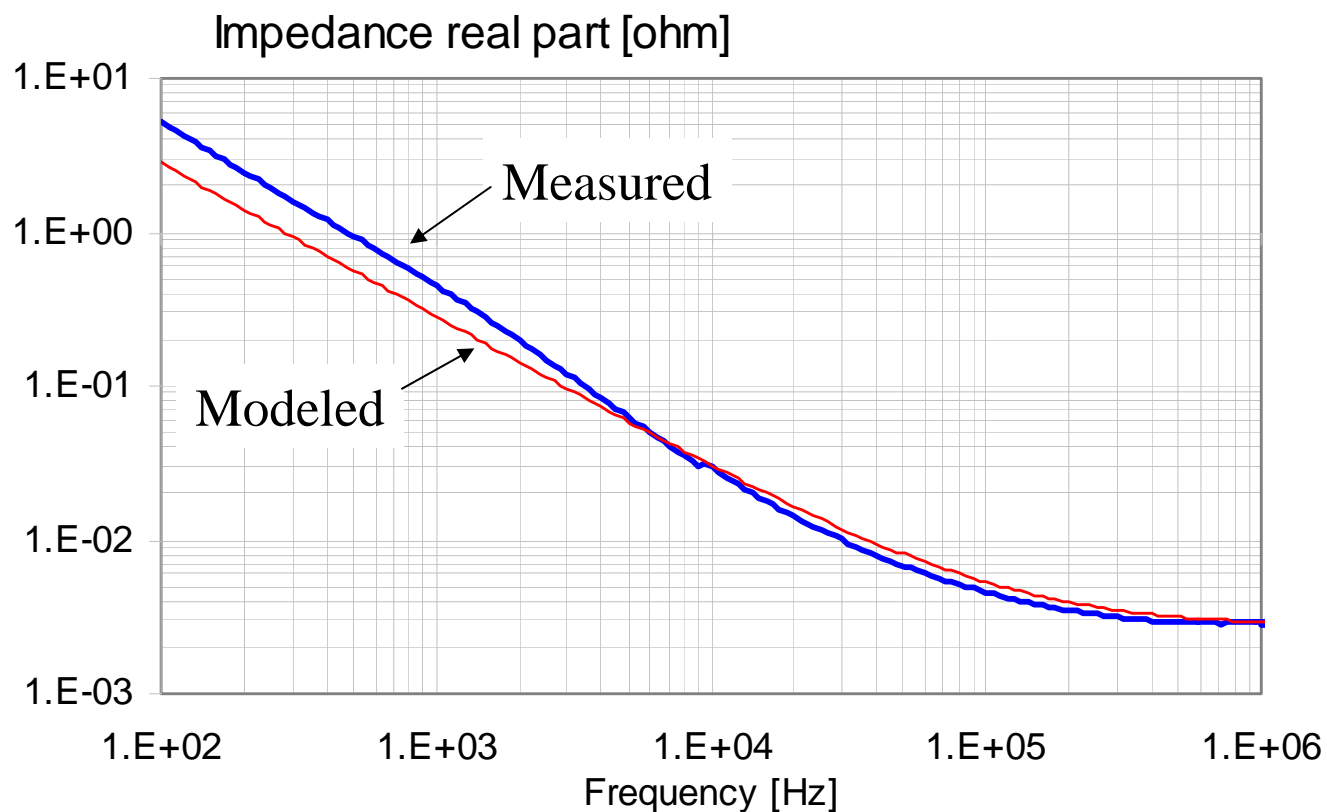

Correlation below SRF

Three loss tangent domains

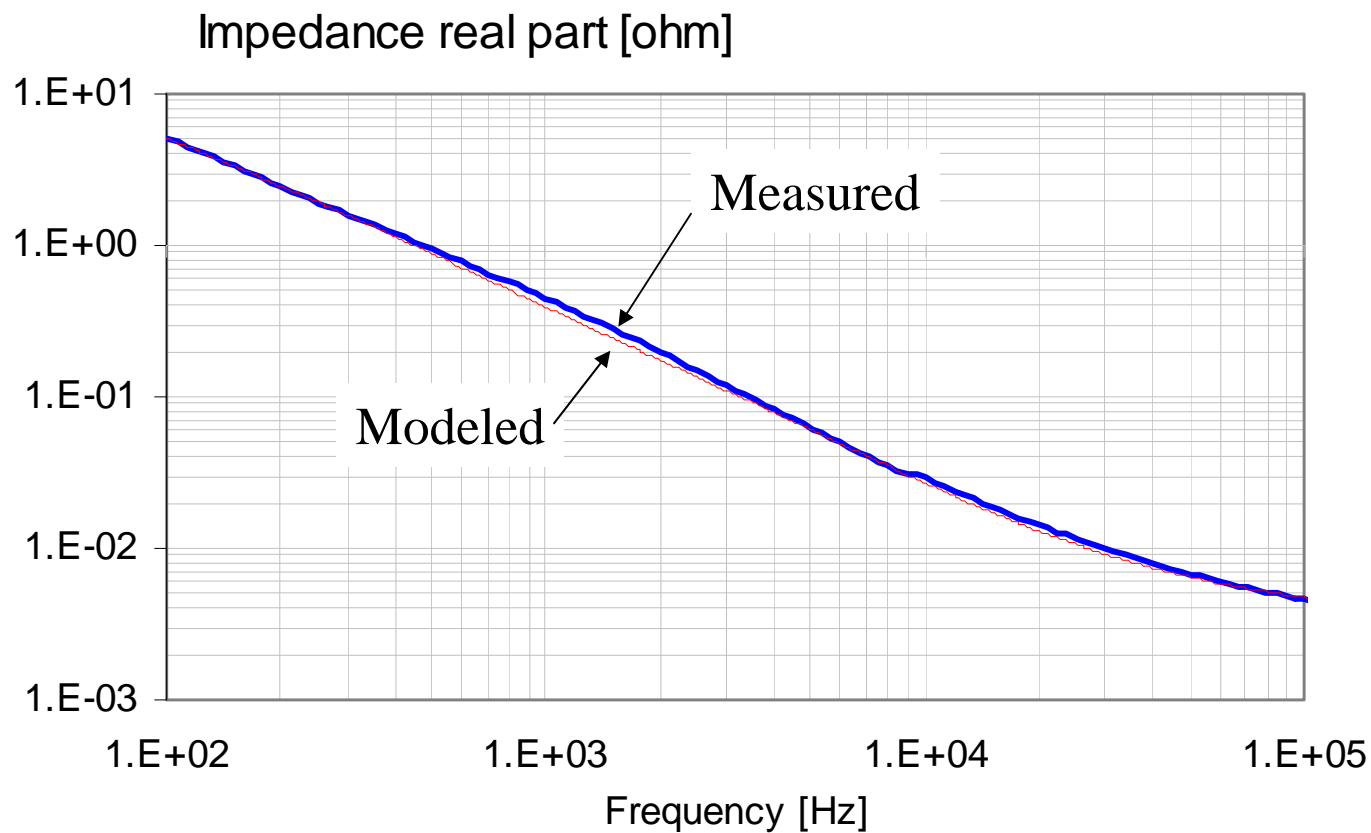

Correlation with unit-cell model

Impedance

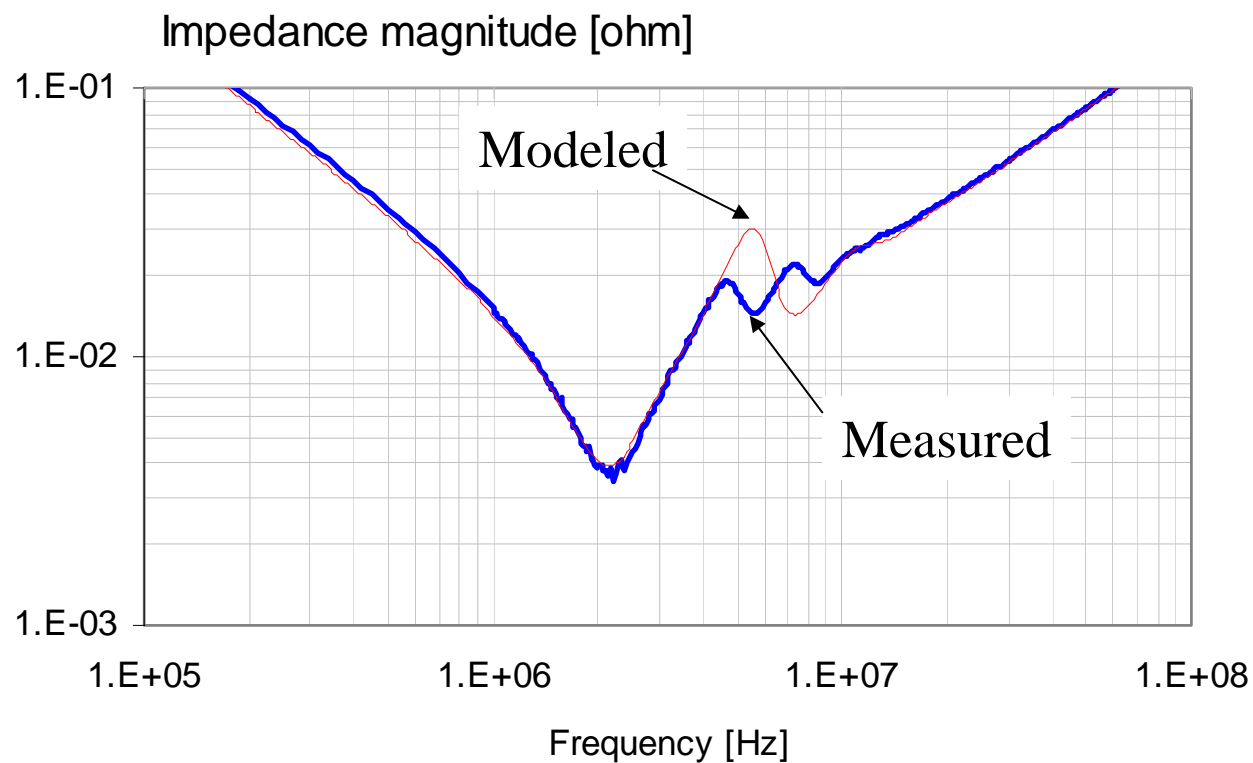

Correlation with unit-cell model

Resistance (ESR)

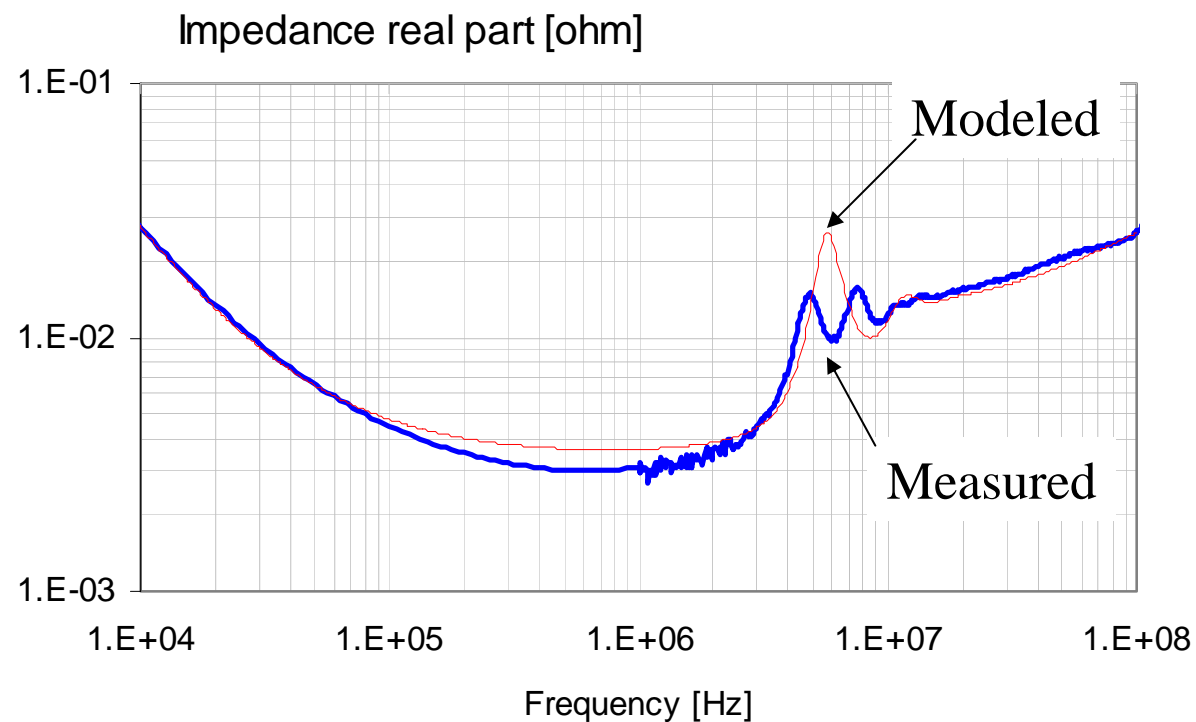

Correlation with lossy-line model

Impedance

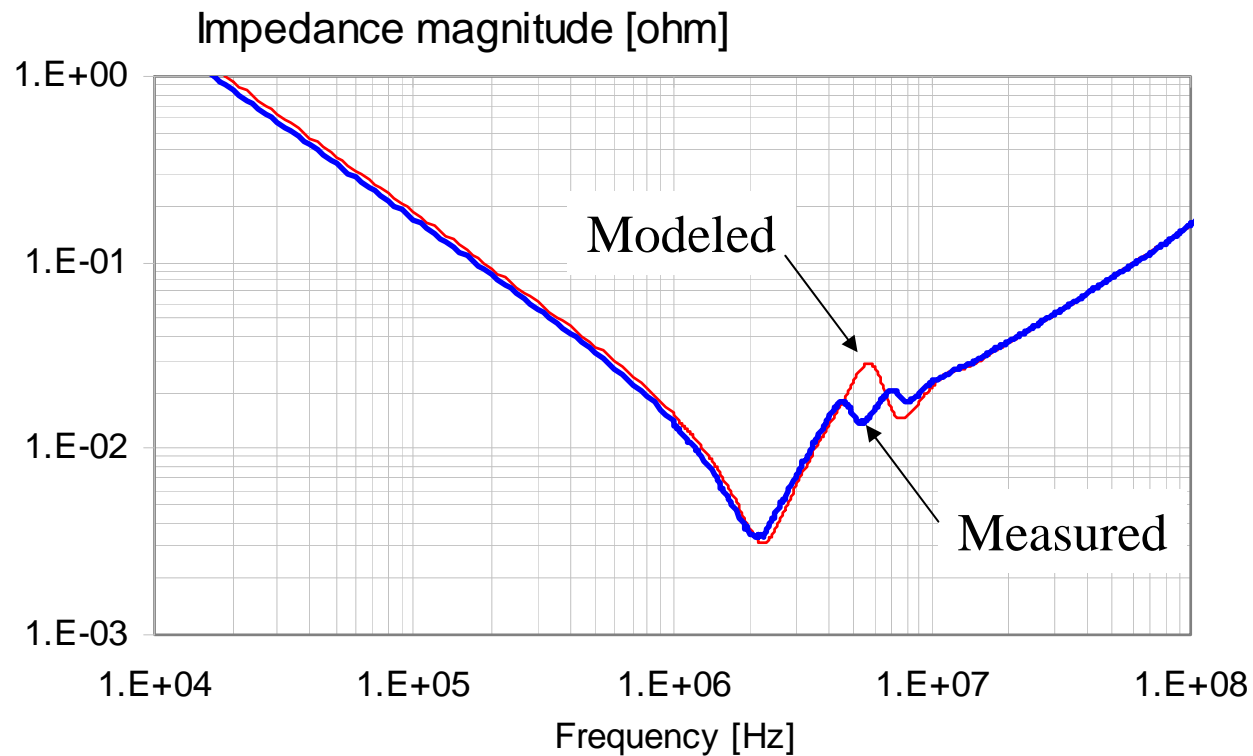

Correlation with lossy-line model

Resistance (ESR)

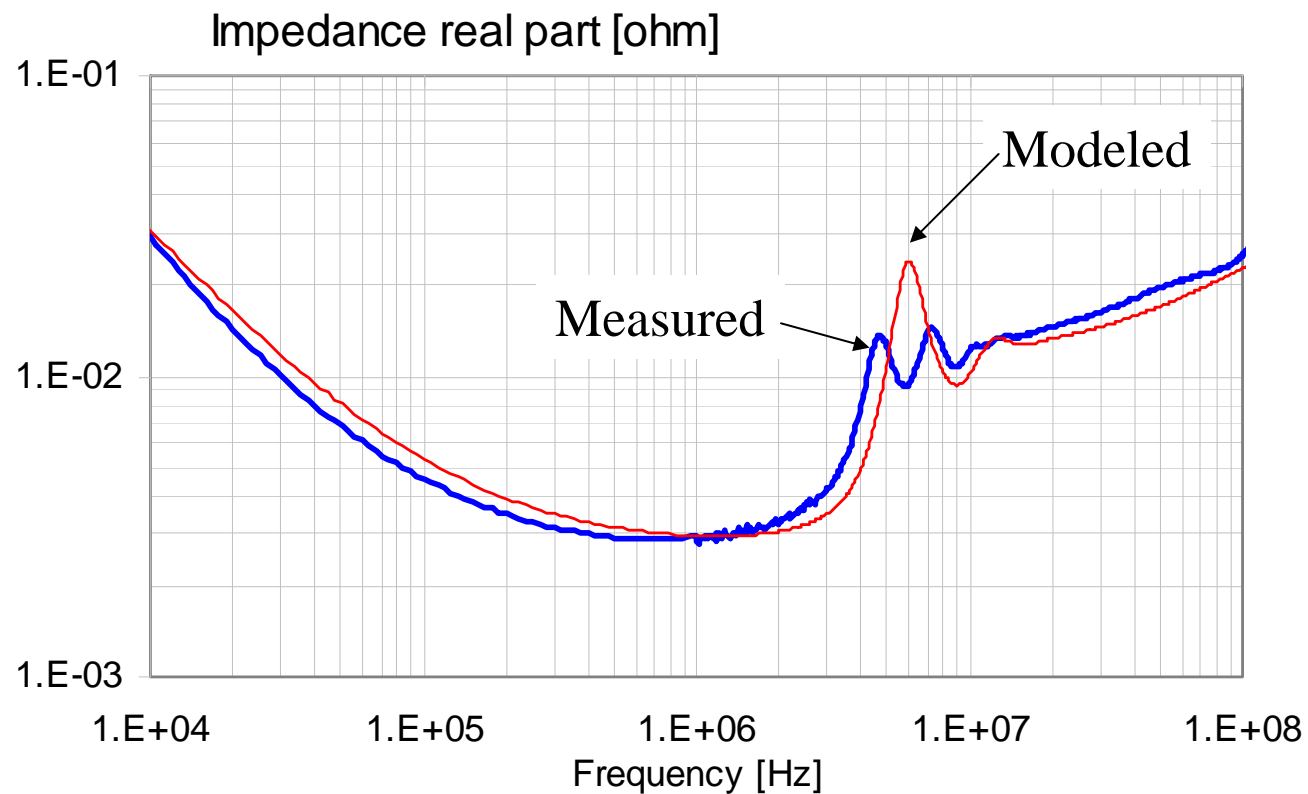

Conclusions and future work

MLCC model based on periodically loaded transmission lines:

- Very simple
- Guaranteed to be causal
- Captures primary and secondary resonances
- Captures $C(f)$ and $R(f)$ below SRF

Coupling among capacitor plates is not captured

THANK YOU