

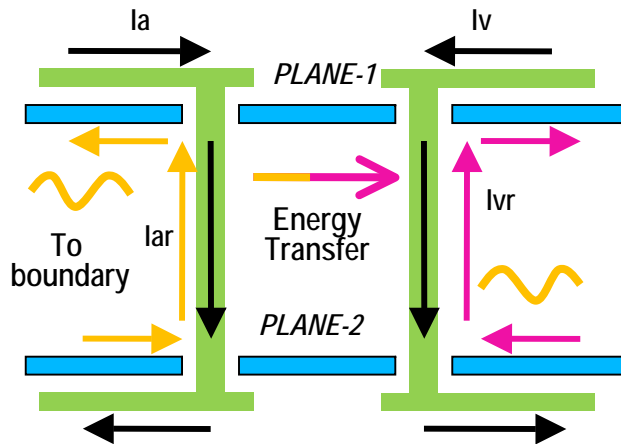

Cross Talk in Via Pin Fields, Including the Impact of Power Distribution Structures

- Gustavo Blando, Jason Miller
- > Doug Winterberg, Istvan Novak
- > DesignCon2009, Santa Clara, CA, February 2-5, 2009

Cross Talk Between Vias



$$Z_{ij}(\omega) = Z(\omega) \sum_{n=0}^{\infty} \sum_{m=0}^{\infty} \frac{\chi_{mn}^2}{w_x w_y (k_{xm}^2 + k_{yn}^2 + Z(\omega)Y(\omega))} f(x_i, y_i, x_j, y_j)$$

Yuriy Shlepnev

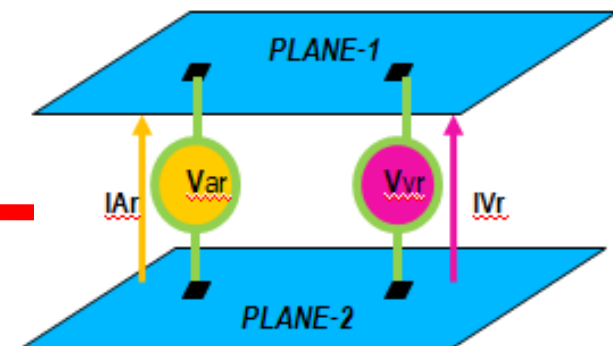

[1] Christian Schuster, "Developing a Physical Model for Vias", Proc. of DesignCon 2006, Jan.31-Feb.3 2006, Santa Clara, CA.
 [2] Giuseppe Selli, "Developing a Physical Model for Vias - Part II: Coupled and Ground Return Vias", Proc. of DesignCon 2007, Jan.29-Feb.1 2007, Santa Clara, CA.

- Crosstalk will also depend of the following structural interactions:
 - > Proximity to other structures (GND, PWR, SIGNAL vias)
 - > Plane boundaries
 - > Plane perforations
 - > Frequency (fields will propagate with different intensity at different frequencies)
- In this paper though simulations and measurement, we'll study how cavity coupling can be altered by these structural interactions

Outline

- First Section: Cavity Modifications (Proof of Concept)
 - > Crosstalk computation from E-Fields
 - > Cavity crosstalk for different boundaries
 - > Fields in the presence of GND blades
 - > Plane perforations and it's effect on the cavity model
- Second Section: Measurements and Simulations
 - > Test board description
 - > Measurements and Post-Processing
 - > Measurement correlation
 - > Additional via pattern simulation
- Summary and Conclusion

Boundary Impact On Crosstalk

- Absorbing vs. Magnetic (Open) boundary (observed on a diagonal line)

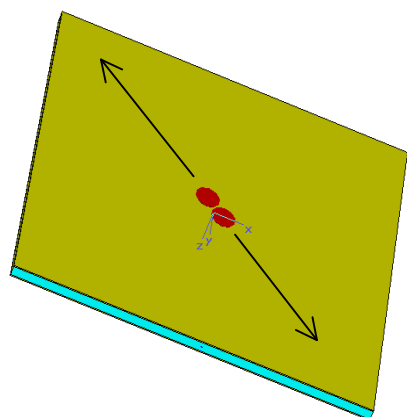

Absorbing Boundary S21[dB]

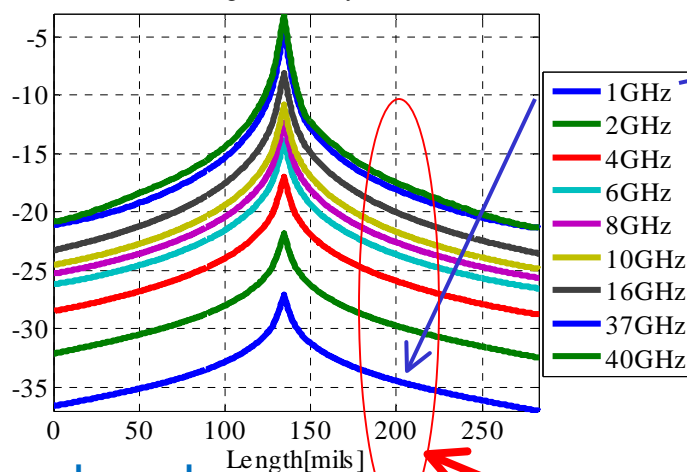

Magnetic Boundary S21[dB]

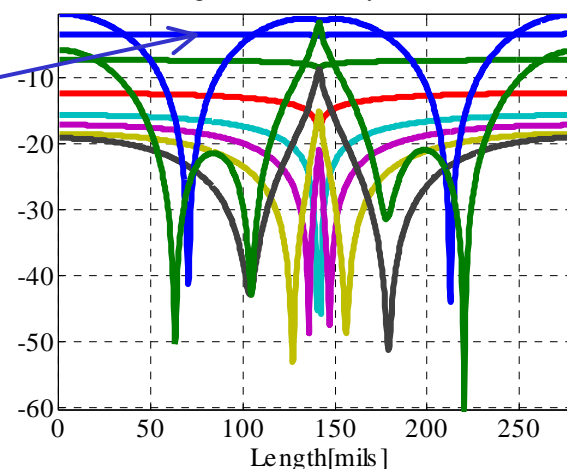

Maximum crosstalk in open boundary correspond to minimum crosstalk on absorbing boundary

Boundary selection plays an important role in via analysis particularly for small or irregular planes cases

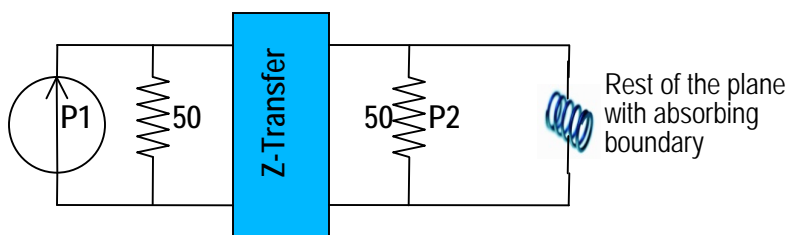

High-Pass-Filter (Absorbing-Boundary)[dB]

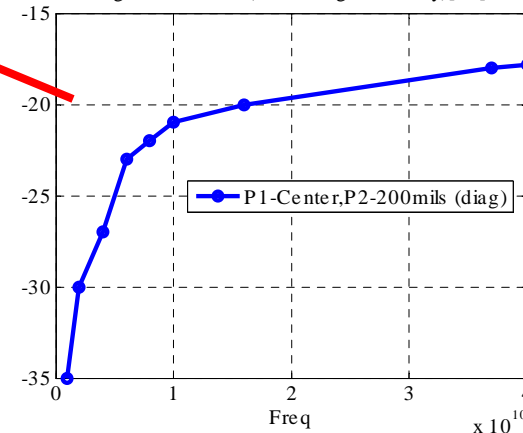

Fields With GND Blades (1)

- GND blades have been added to shield the fields, and simulated with (E and H b
- An observation line 20mils from the ground blade wall has been created to observe the field leakage through the blades opening

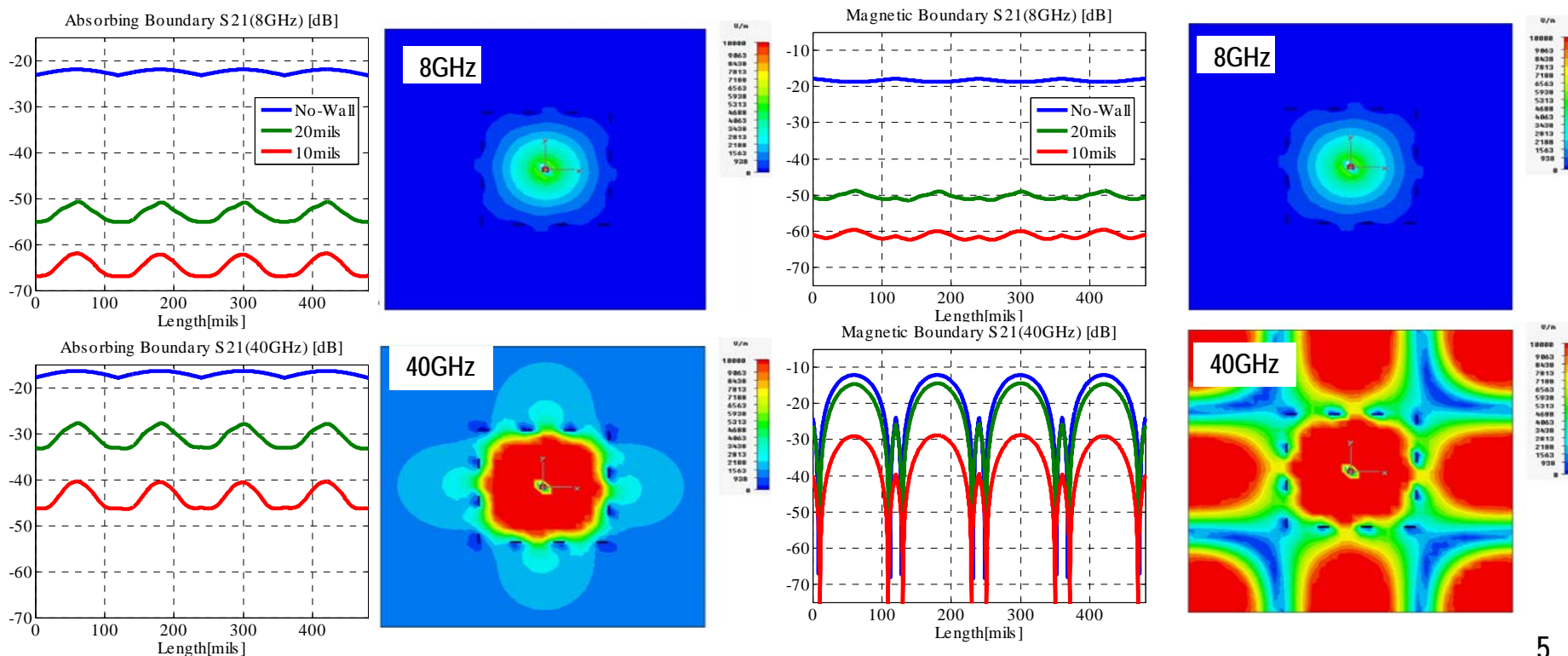
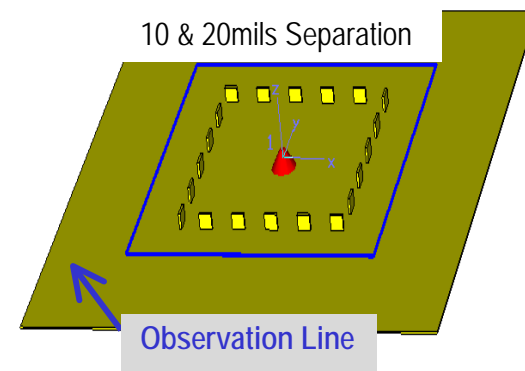

Fields with GND Blades (2)

Return Current Example

- A closed wall was created between planes and a single ended via was placed on the center of the structure, the wall distance from the center was swept from 20mils to 80mils (looks like a coax)
- As the wall get further way from the via, we start to observe resonances due to the destructive field superposition of incident and scattered fields

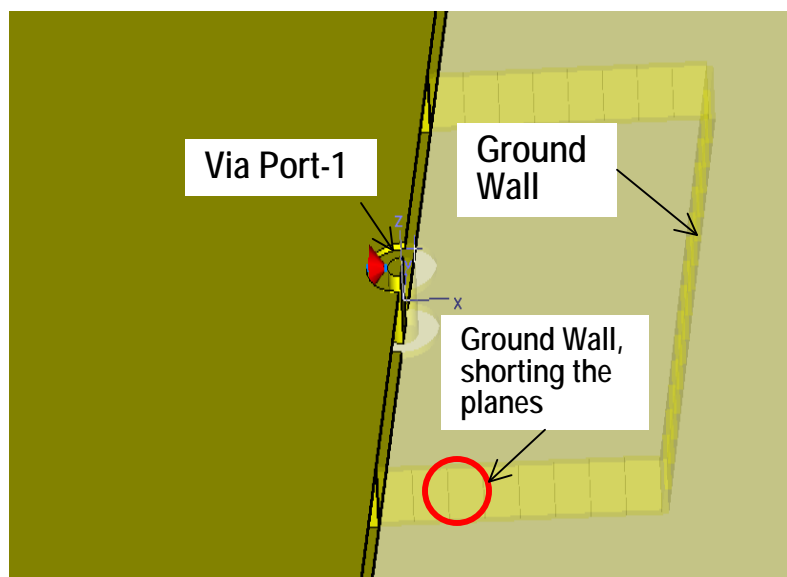

Due to the way we connect to the via, we excite the cavity, and the cavity impedance (with it's resonances) is what creates the signal return path.

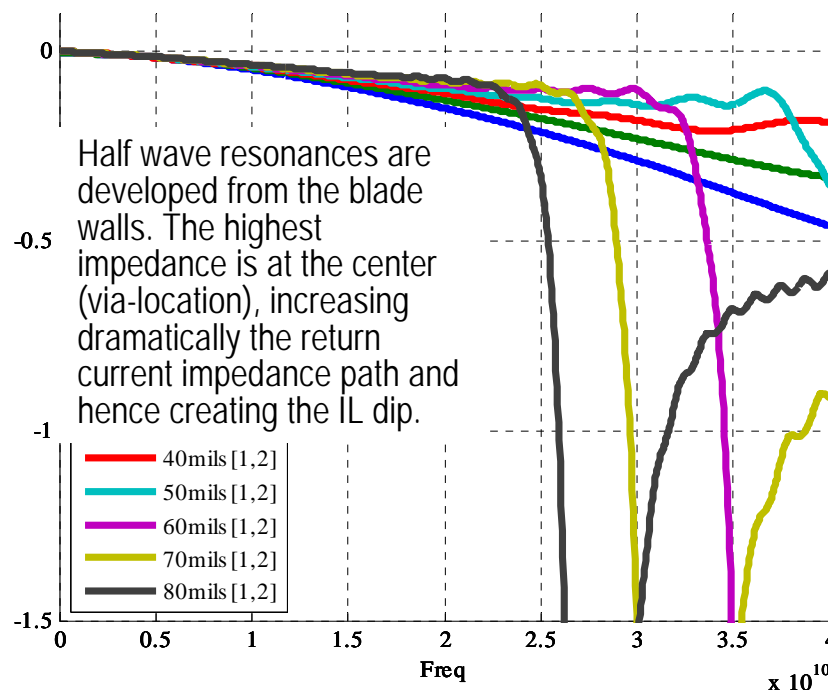

Plane Perforations

- Perforation area was kept constant between different number of holes (hole size changes for equidistant hole separation)
- 50% area cut 14 holes per side (small holes)
- 50% area cut 6 holes per side (large holes)
- High loading sensitivity of hole size.
- !!!It's not how much you cut, but rather how you cut it!!!

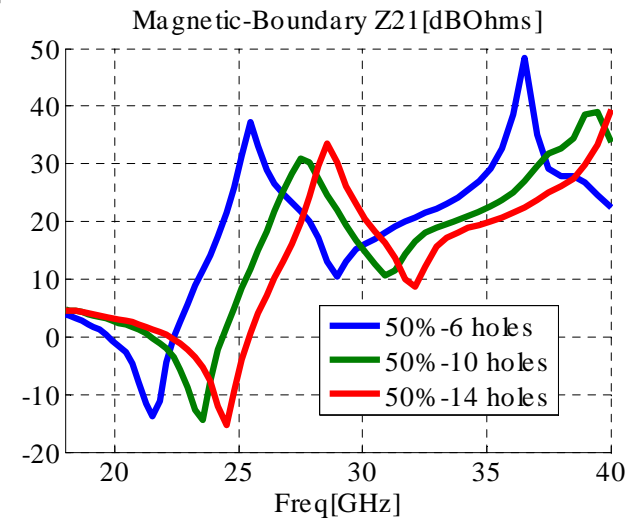
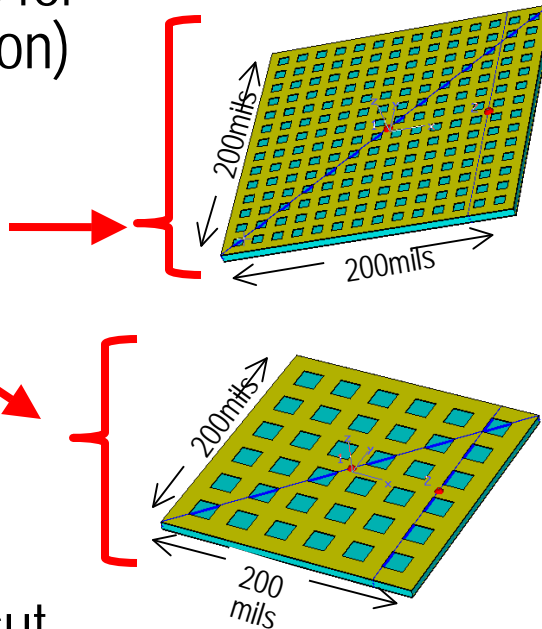

Please note: when modeling vias in perforated areas, the analytical plane impedance results might be different than the real structure. It'll depend of the number and more importantly, the size of perforations.

Summary So Far

- Absorbing boundary, ok for big-boards and centered vias, for other cases correct boundary selection is of paramount importance
- GND Blades shield:
 - > The effectiveness of the shield is directly related to the separation between blades and the wave length at the frequency of interest
 - > On a reflective boundary, for small planes, the shielding effectiveness of the blades is greatly reduced.
 - > The way we inject current on a via excites the cavity. The frequency dependency of the return current depends of the cavity impedance at the via location. A via surrounded with GND near by might not experience dips on the frequency of interest, but it will !!! at a higher frequency
- On perforated planes:
 - > Cavity resonances are pushed to lower frequency due to the loaded characteristics of the planes
 - > On regular pattern, the size of the perforation has higher sensitivity than the percentage of area cut

Test Card Structure

- Test-tabs:
 - > GND vias connecting the GND planes on the periphery
 - > Differential case with 0,1 or 2 GND near by
 - > Plane with and without perforations
 - > VNA SOLT measurements taken, using GSSG 500um probes

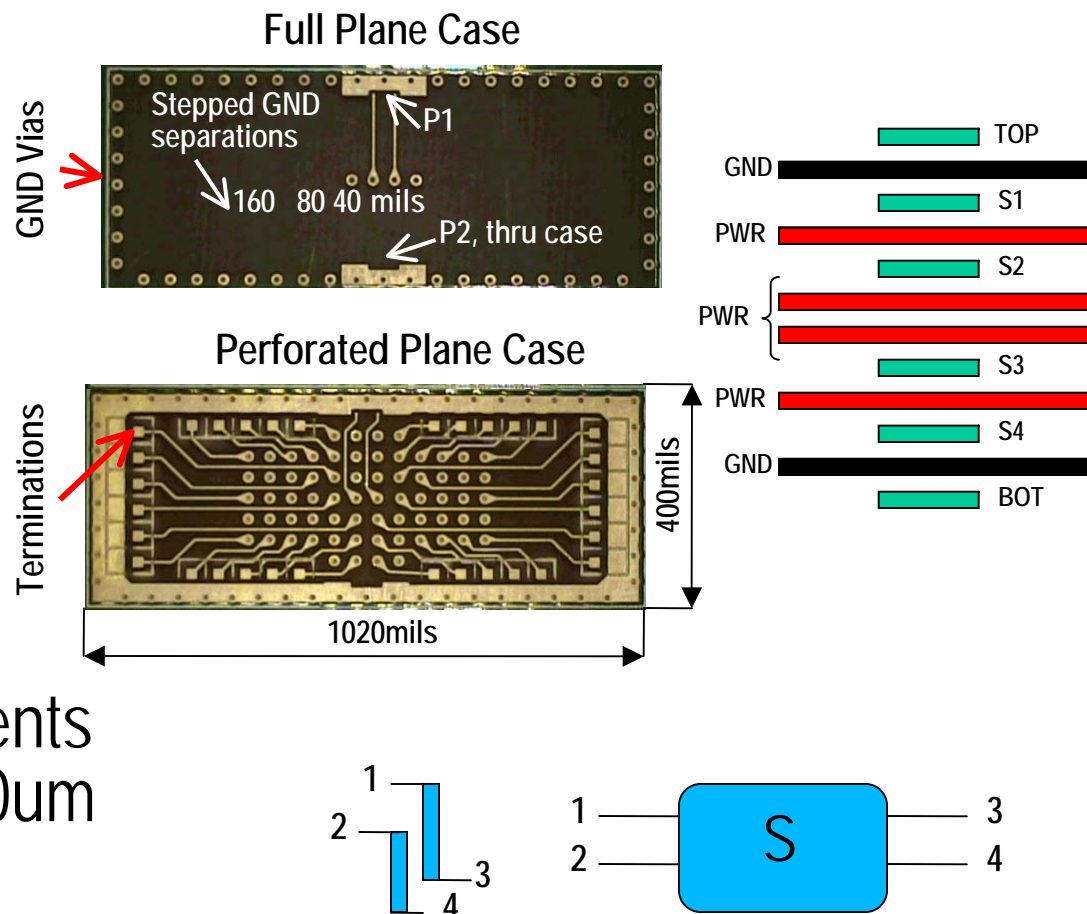

Full Plane (0,1,2 GND cases) 40mils

- Let's look at the following cases:
 - > Two signal vias, no GND vias
 - > Two signal vias, one GND via 40mils away
 - > Two signal vias, two GND vias 40mils away signals on each side
 - > Signal vias in a through configuration (no-stub)

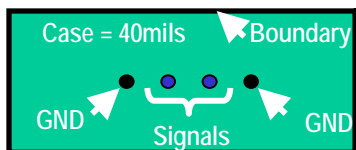

Open cavity boundary

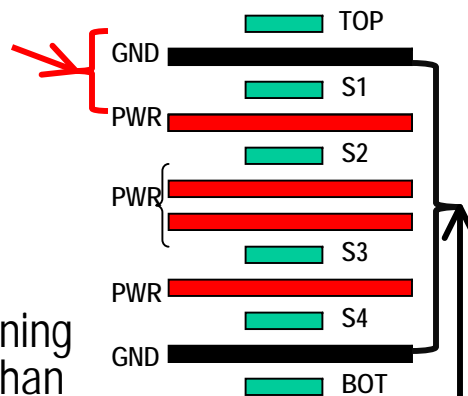

Shorted cavity boundary

- Resonances on IL and NEC:
 - > Due to plane boundaries (High-Z)
 - > GND vias not very effective containing energy, but 0-GND clearly worse than 2-GND
 - > Low frequency attenuation, higher for 0-GND, more of the energy is diverted to the planes (not-contained by the ground vias)

- So, which boundary is causing these reflections?
 - Maybe obvious but always good to check against something!!!!

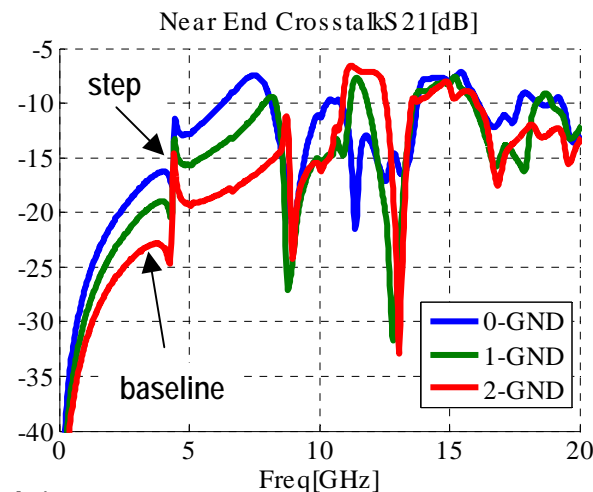
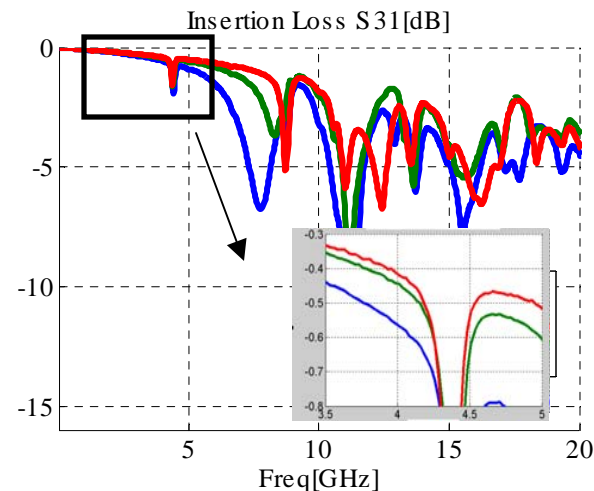

Model Creation Spelled Out

- The twist of this model (as compared to the all-ground case), is that we have both power and ground

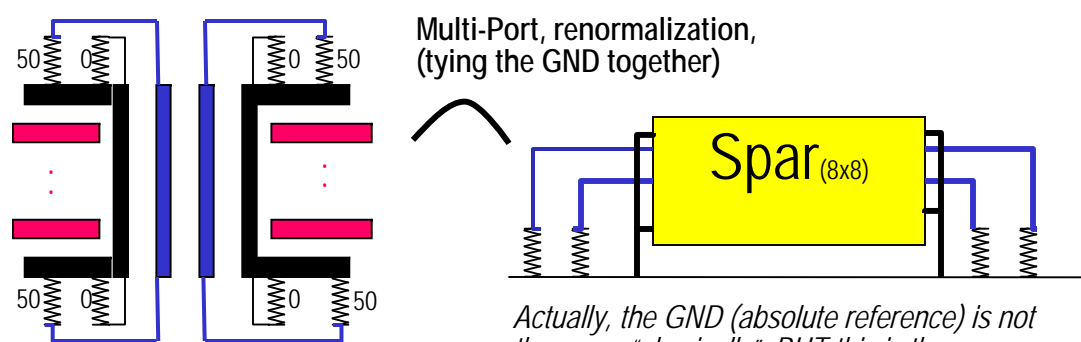
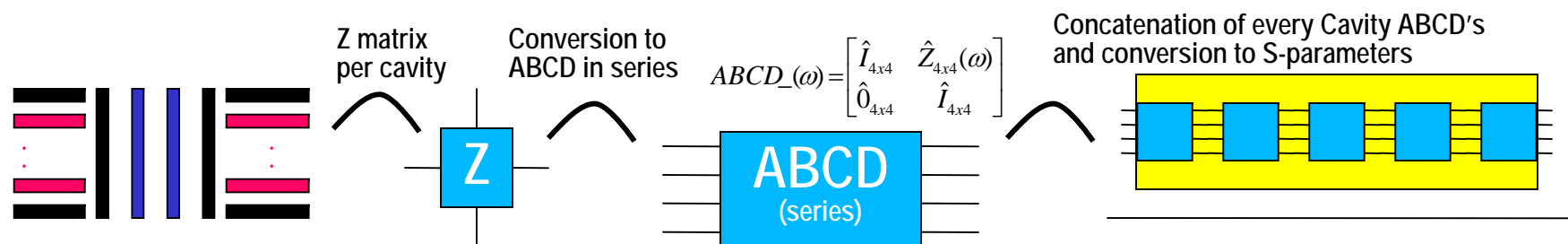

Actually, the GND (absolute reference) is not the same "physically", BUT this is the same as when we are measuring with VNA

Extracting the inner matrix (4x4) and obtaining the pair of vias S-parameters

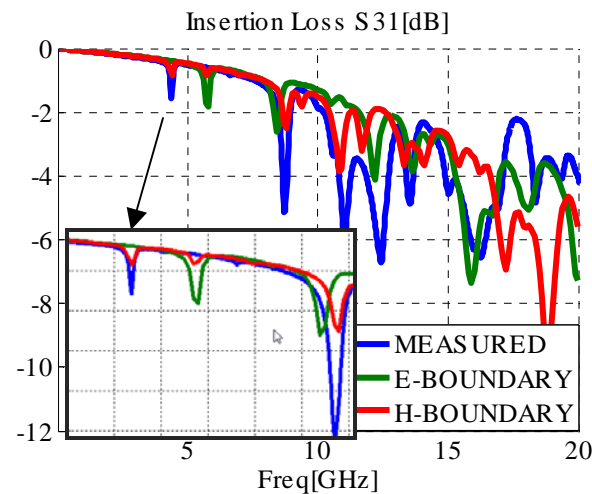
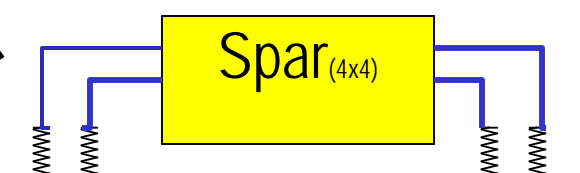

- Then using the Cavity formula to calculate the Z for either open or shorted boundaries, I can compute the analytical S-parameters for both cases

GND Via Separation (Full Plane)

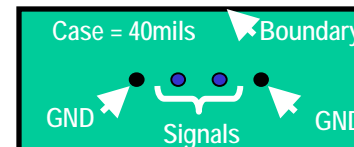

- Let's compare now, the cases having two GND vias but with different separation:

- > Insertion loss on 160mils similar to no-gnd. (all energy has already been diverted to the boundary)
- > With 40mils GND separation an improvement on crosstalk is observed
- > With 80mils GND separation the crosstalk improvement is small

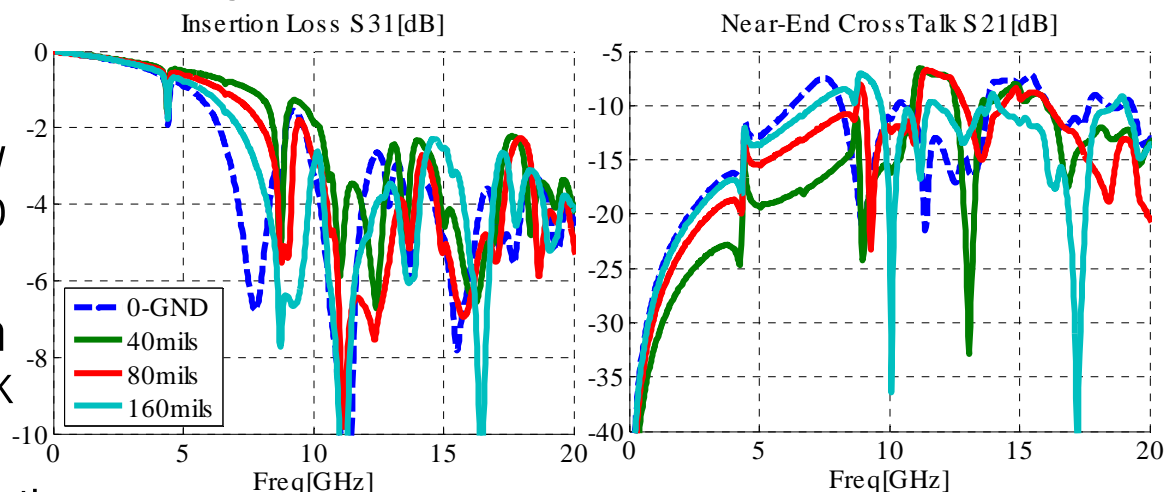

- Modifying the structure, by back-drilling one of the GND vias we see:

- > Big dip in the insertion loss GND ("power") via is resonating

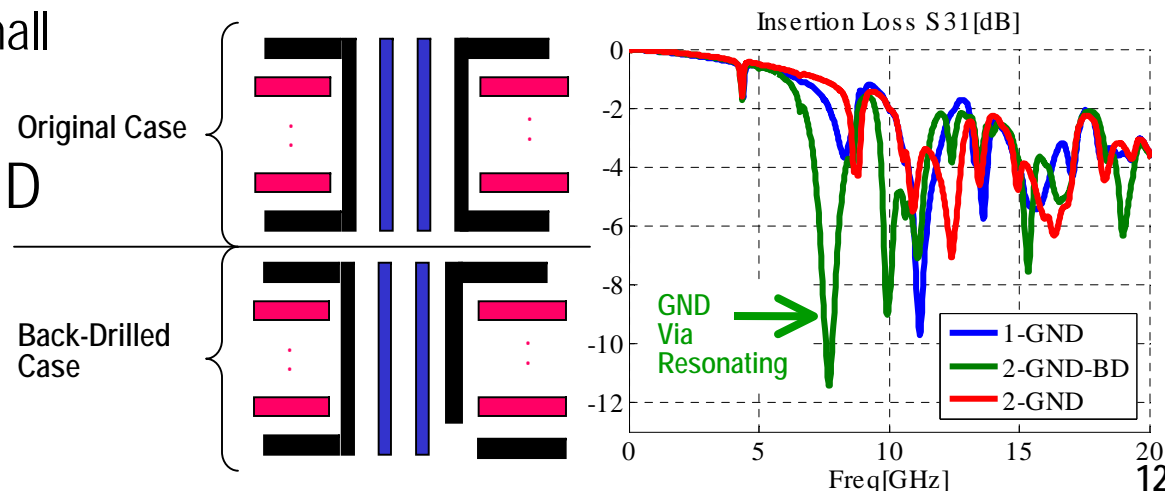

Vias Behavior Inside Perforated Pin-Fields

Termination Locations

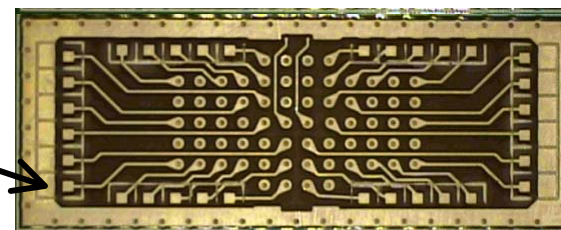

Perforated Planes
40,80,160mils

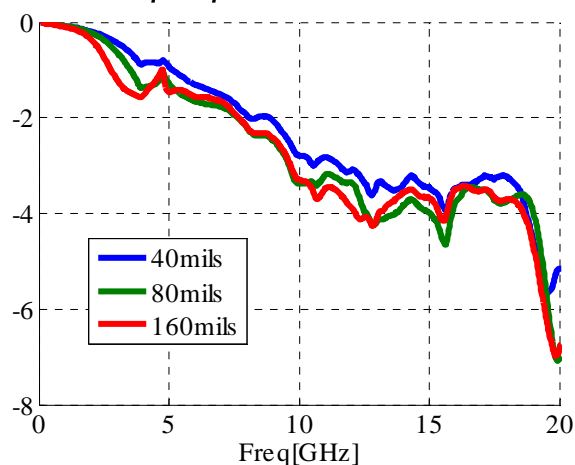

Comparison, perforated vs. full-plane (non-perf)

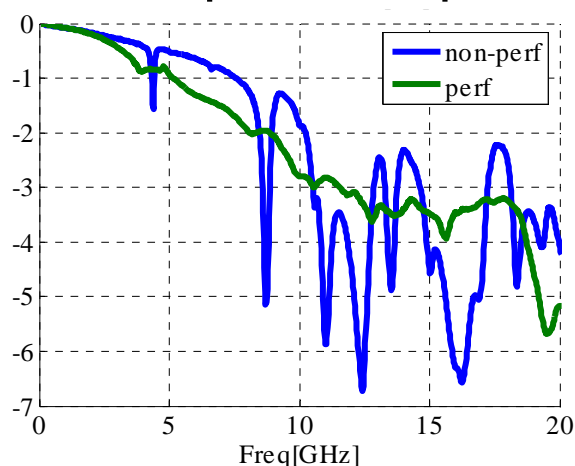

Perforated, with and without terminations

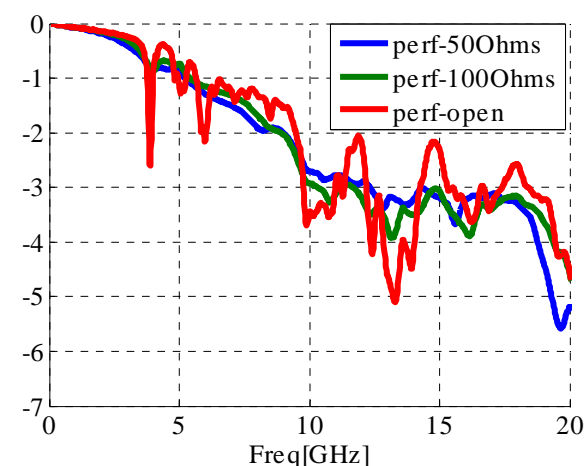

Near-End Cross Talk S21 [dB]

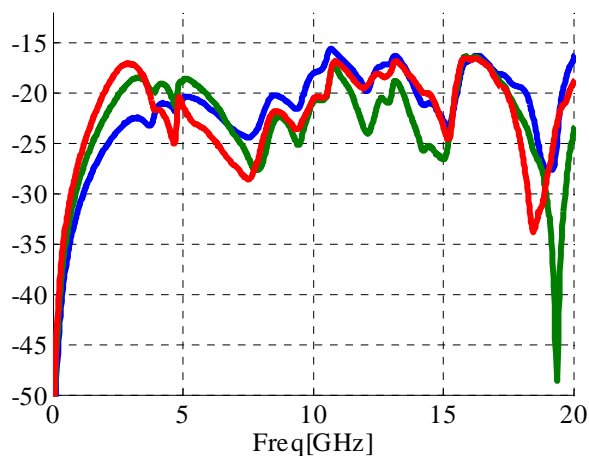

Near-End Cross Talk S21 [dB]

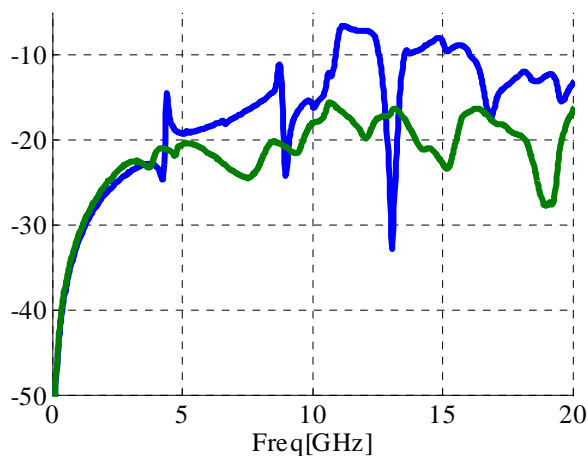

Near-End Cross Talk S21 [dB]

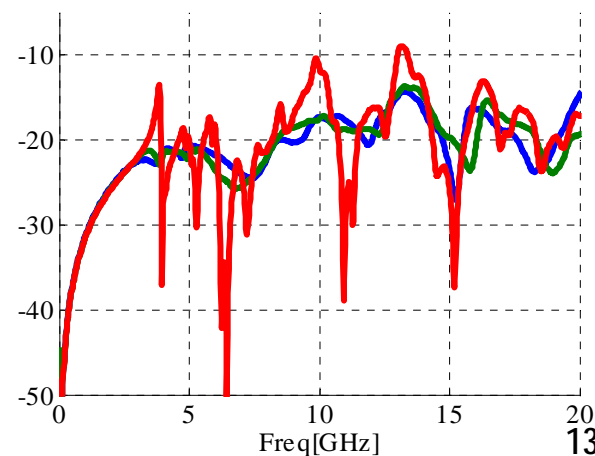

Field Solver Correlation

- Before performing additional simulations, correlations to measurements on the test structure were done

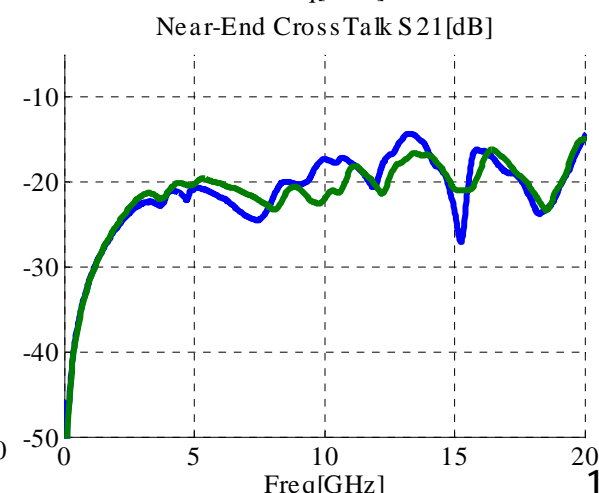
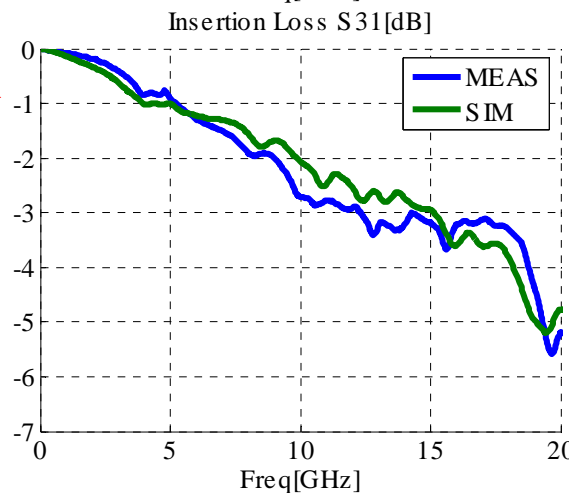
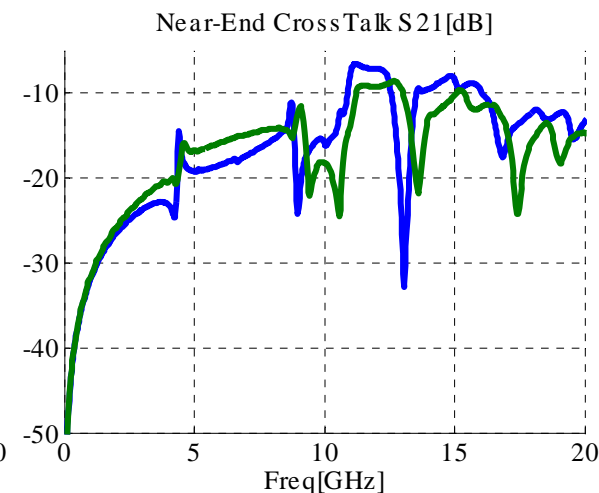
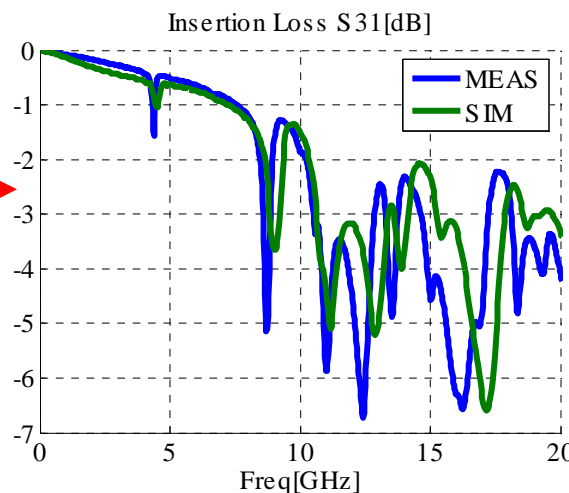
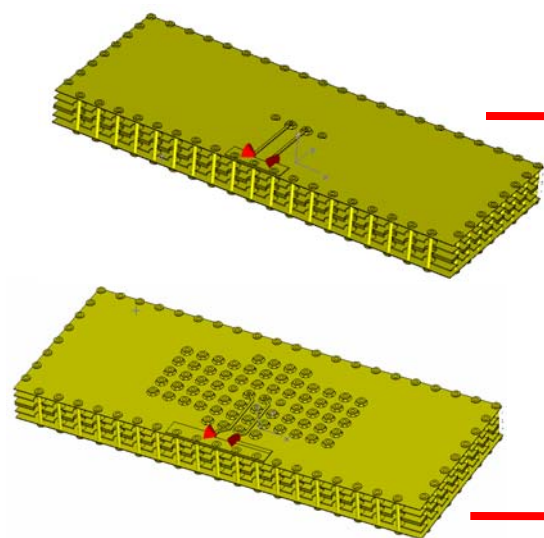

- Differences between structure and simulation deck:
 - Cross-section not completed
 - 2nd Order Debye vs. Sakar
 - Terminations right on the ports

Additional Differential Simulations

- An offset via pattern, including three differential pairs have been simulated
- A total of six grounds have been included on the structure
- In different simulation cases, two of those GND have been replaced with power connected to different layers

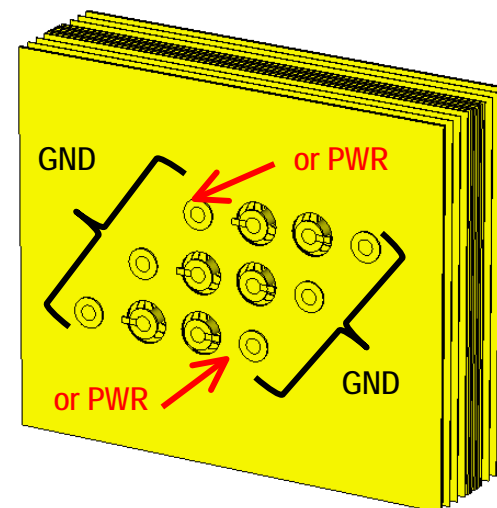

- Cases:

- > B1: baseline (all gnd)
- > B1_PT: power-via to top power plane
- > B1_PM: power via to middle power plane
- > B1_PT B: power via to top and bottom power plane

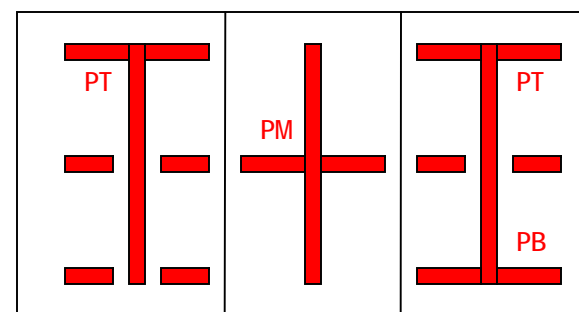
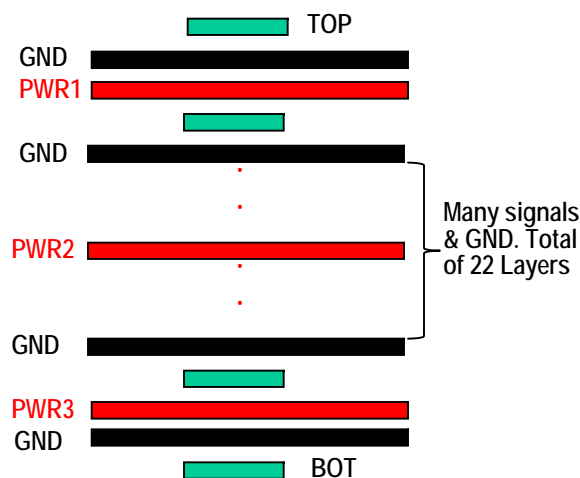

PT: Power via connected to the top plane
 PM: Power via connected to middle plane
 PT,PB: Power via connected to top and bottom plane

Offset Pattern Simulations Results

Single Ended S-Parameters

- The baseline case shows the best (resonance free) insertion loss profile, return loss, near and far end crosstalk
- B1_PT case, shows an steep resonance at around 10GHz on the IL (insertion loss)
- B1_PM, seems to have more attenuation, and a resonance close to 20GHz on the IL
- B1_PT B shows the closest profile to the baseline case

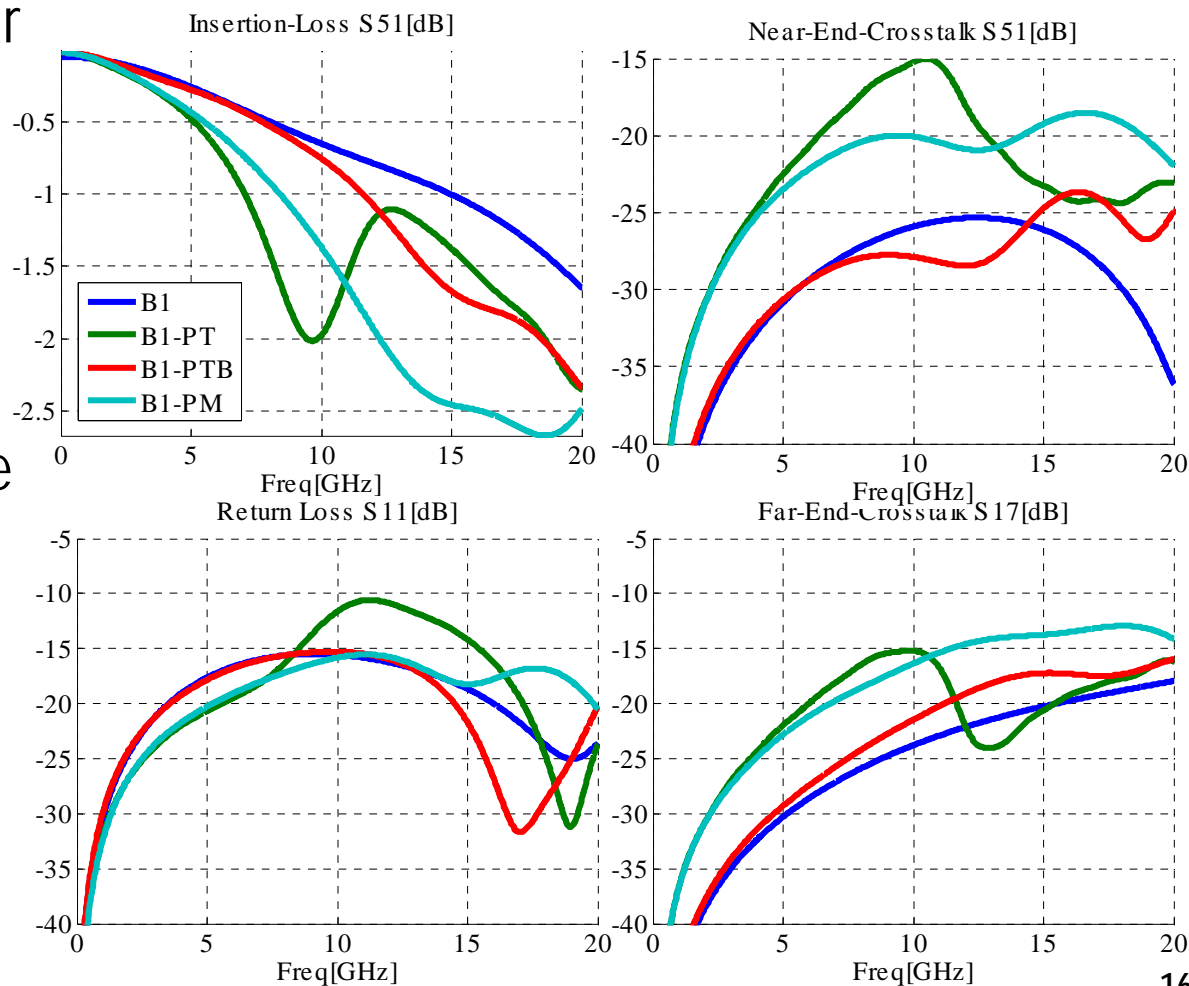

Electric Field (PT Case)

- Plotting the fields on the PT case (via connected to the top most power plane only), we can see how the power via is resonating
- The resonance is facilitating the propagation of energy to the other signal via
- Same effect observed as the "signal via" stub effect
- *Power vias connected to power planes leaving large stubs, (low-impedance at one end, high impedance at the other) will resonate with $\frac{1}{4}$ wave length pattern*

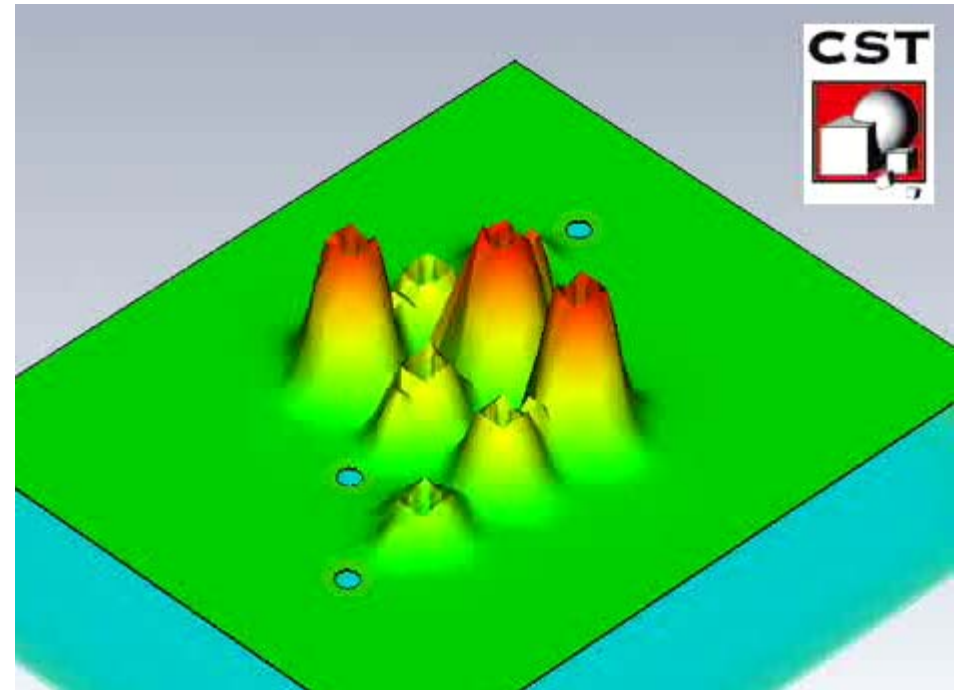

			GND
	SIG	SIG	GND
PWR	SIG	AGR	PWR
GND	SIG	VIC	
GND			

Offset Pattern Simulations Results

Mixed Mode S-Parameters

- By looking at the mixed-mode S-parameters we can observe similar trends
- Since the MM S-parameters will tend to exacerbate the differences (asymmetries) in some cases we can observe more well defined resonances

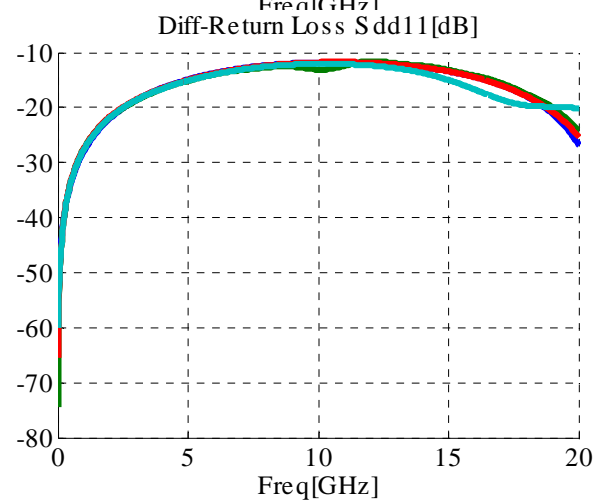
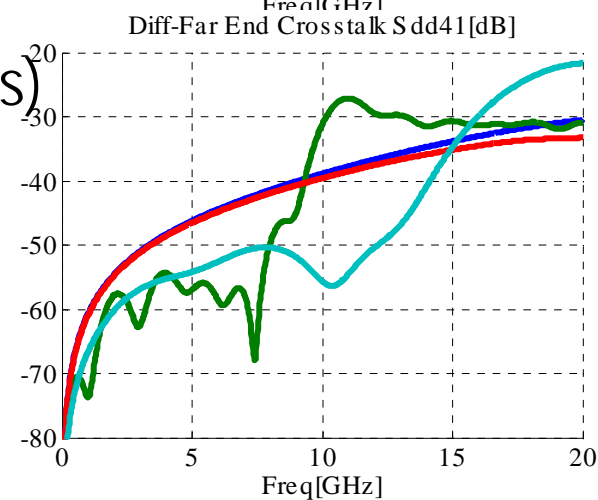
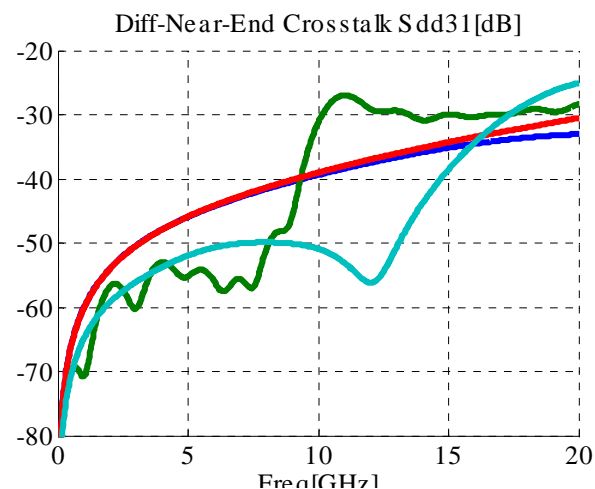
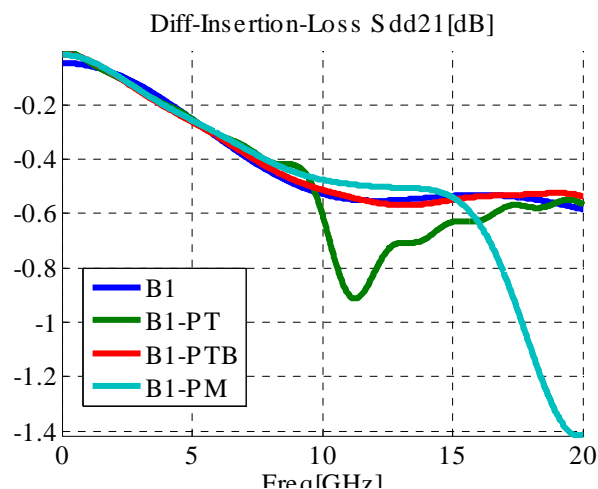

Summary and Conclusion (1)

- Through measurements and simulations we've shown:
 - > Insertion loss and crosstalk changes dramatically whether vias are in isolation or inside a perforated pin-field
 - > With two GND vias side to side (typical case), it has been shown than
 - $\text{SIG-to-GND} > 3 * \text{SIG-to-SIG}$: The effect of GND via is negligible
 - $\text{SIG-to-GND} < 2 * \text{SIG-to-SIG}$: We can start seeing the effect of GND vias proximity
 - $\text{SIG-to-GND} = \text{SIG-to-SIG}$: The effect of GND vias is appreciable
 - > Power vias will resonate depending how they are connected to the stack, in the worst case (connected to only one side), it can form a $\frac{1}{4}$ wave resonator, sucking energy at lower-frequencies and impacting both insertion loss, and helping propagate energy to increase crosstalk between signal vias.



Thanks

- ▶ Gustavo Blando
- > Gustavo.blando@sun.com